



## PACKAGED ROOFTOP UNITS WITH R-410A



- High efficiency
- Superior reliability
- Compact system
- Low sound level
- Energy recovery
- Variable speed EC fans

# 50FF 020 - 093 / 50FC 020 - 099 R-410A

Nominal cooling capacity 22.3 - 97.0 kW  
Nominal heating capacity 21.9 - 99.6 kW



The **50FF/FC R-410A** packaged rooftop range consists of autonomous compact air-air units of horizontal design, rooftop type.

■ **50FF 020 - 093 series:** for **cooling-only** operation.

■ **50FC 020 - 099 series:** for **reversible heat pump** operation.

The range of available capacities in the series allows for the air conditioning of medium and large surface areas which are common in shopping malls, food retail, logistics and many other commercial and industrial applications.

50FF/FC units are designed for optimized part-load management in achieving the highest levels of seasonal efficiency, exceeding the limits set by regulation.

With its mono-block lightweight construction, the units feature a self-supporting frame, designed to ease the installation and maintenance works.

The units integrate the latest technological innovations:

- Multi-scroll compressors in tandem.
- Electronic expansion valves.
- Variable speed EC fans.
- Auto-adaptative microprocessor control.

For maximum adaptability, a number of options is available to meet any operating requirement:

- Exhaust air energy recovery.
- Economizer.
- Indoor air quality management.
- Installation roofcurbs.
- Zoning with variation of airflow.
- Auxiliary heating modules.
- Extended operation limits.



CARRIER participates in the ECP programme for RT  
Check ongoing validity of certificate:  
[www.eurovent-certification.com](http://www.eurovent-certification.com)

## CUSTOMER BENEFITS

### Outstanding performance

The 50FF/FC units are designed for optimized part-load management in achieving the highest levels of seasonal efficiency, exceeding the limits set by regulation.



The unit integrates the latest technological innovations:

- Optimized multi-scroll compressors in tandem with excellent full and part load efficiencies.
- Electronic expansion valves.
- Outdoor EC fans with variable speed.
- Supply EC plug-fans with direct drive and variable speed.
- Auto-adaptative microprocessor control.



### Easy and fast installation

With its mono-block lightweight construction, the 50FF/FC units feature a self-supporting frame, designed to ease the installation and maintenance process.

The units are connected directly to an air distribution ductwork without additional elements or equipment, pipes, cables, etc. taking no floor space at all. This design reduces the cost of installation, facilitates a quick connection and ensures reliable operation.

- Vertical supply/return airflow configurations are ideal for new construction or retrofit projects.
- Horizontal airflow configurations are ideal for replacement or applications such as through-the-wall where sound must be attenuated before the duct penetrates the roof.



### Adaptability

The range offers a wide range of options and a large set of configurations to customize the unit according to your needs:

- Exhaust air energy recovery.
- Economizer.
- Indoor air quality management.
- Adjustable or adaptation roofcurbs.
- Auxiliary heating systems.
- Extended operation limits up to -15°C in heating.
- 4 zone management with airflow control option.
- Heat recovery water coil.
- Low return temperature option for storage applications.

### Superior reliability

The 50FF/FC range has been designed to ensure robustness throughout the lifecycle of the units. The high-reliability of the units is the result of **high-quality material and components** combined with the **highest quality standards** in terms of manufacturing and laboratory testing.



### Low sound levels

The 50FF/FC units provide a low-noise level during operation thanks to design optimization and the latest technology to meet the most exigent requirements.

Up to **70%** of the operation time below half-load.

Sound level reduction in partial load operation.

**Night operation mode** available with free-cooling and disabling compressors. This also helps to reduce the sound level during night periods.

### Indoor air quality

The 50FF/FC range offers a wide range of technological features dedicated to improve and maintain the highest level of indoor air quality:

- Ventilation
- Filtration
- Quality sensor
- Airflow control
- Active technologies under request

Discover more about Carrier's approach to Healthy Buildings on <https://www.corporate.carrier.com/healthybuildings/>

# KEY FOR CONFIGURATION

A	B	C	D	E	F	G	H	I	J	K	L	M	N	O	P	Q	R	S	T	U	V	W	X	Y
50FC	020	A	4	A	B1	LL	000	S	N	A	H	S	000	0000	0000	0	0	AA00	00	A00	000	AA00	0000	0000

## A: Unit type

50FF: air/air cooling-only (0020 to 0093)  
50FC: air/air heat pump (0020 to 0099)

## B: Unit model

1 circuit: 0020 / 0028 / 0037 / 0040 / 0045 / 0047  
2 circuits: 0052 / 0058 / 0062 / 0070 / 0074 / 0086 / 0093 / 0099

## C: Version of the series

A: Current version

## D: Electrical power

4: 400V / 3ph + N / 50Hz  
5: 400V / 3ph / 50Hz

## E: Type of refrigerant

A: R-410A

## F: Flow + Assembly

B1: Standard.  
B2: Standard. Economizer, 2 dampers  
BF: Standard. 100% fresh air  
B3: Standard. Economizer, 3 dampers  
BX: Standard. Axial fan in return section  
BP: Standard. EC plug-fan in return section  
BA: Standard. Cooling recovery circuit with EC plug-fan in return section  
BT: Standard. Return top box with EC plug-fan or centrifugal fan  
BB: Standard. Cooling recovery circuit with EC plug-fan or centrifugal fan in return top box  
BW: Standard. Heat recovery wheel module  
R1: In-line.  
R2: In-line. Economizer, 2 dampers  
RP: In-line. EC plug-fan in return section  
RW: In-line. Heat recovery wheel module

## G: Coil coating : Indoor - Outdoor

LL - Indoor coil - Outdoor coil  
L: Aluminium L: Aluminium  
P: Polyurethane P: Polyurethane  
N: Inera® N: Inera®  
Y: Blygold® Y: Blygold®

## H: Heating

000: Without auxiliary heating  
BAx: Gas burner, 3 power outputs:  
x = F (Low) / M (Nominal) / S (High)  
BBx: Boiler with hot water coil, 3 power outputs:  
x = F (Low) / M (Nominal) / S (High)  
RAX: Electrical heaters, 3 power outputs:  
x = F (Low) / M (Nominal) / S (High)  
HAX: Hot water coil, 2 options:  
x = S (Standard) / F (Very low outdoor temperature)

## I: Protection for low outdoor temperature

S: Without protection  
A: Freeze protection OAT lower than -10°C  
B: Freeze protection OAT lower than -14°C  
C: Freeze protection OAT lower than -10°C + spring shut-off dampers  
D: Freeze protection OAT lower than -14°C + spring shut-off dampers

## J: Supply fan

F: Low available pressure  
N: Nominal available pressure (polypropylene)  
M: Nominal available pressure (aluminium)  
S: High available pressure

## K: Air filtration + droplet eliminator

A: G4  
B: G4+ droplet eliminator  
C: G4 low pressure drop  
D: G4 low pressure drop + droplet eliminator  
E: G4 + M6

F: G4 + M6 + droplet eliminator  
G: G4 + F7  
H: G4 + F7 + droplet eliminator  
I: G4 + F9  
J: G4 + F9 + droplet eliminator  
K: G4 l.p.d. + F7  
L: G4 l.p.d. + F7 + droplet eliminator  
M: G4 l.p.d. + F9  
N: G4 l.p.d. + F9 + droplet eliminator  
O: M6 + F7  
P: M6 + F7 + droplet eliminator  
Q: M6 + F9  
R: M6 + F9 + droplet eliminator  
S: F7 + F9  
T: F7 + F9 + droplet eliminator  
U: F9 + F9  
V: F9 + F9 + droplet eliminator

## L: Outdoor fan

L: AC (2-speed)  
H: EC (electronic)

## M: Insulation

S: Standard insulation  
M: Euroclass A2-s1, d0 (M0) insulation

## N: Indoor circuit

000 - Without optional accessories  
A: Condensate drain pan in stainless steel  
A: Room overpressure management  
A: Filter fouling detector

## O: Outdoor circuit

0000 - Without optional accessories  
A: Fresh air safety grid  
A: Outdoor coil protection grid  
A: Antivibration mounts  
A: Droplet eliminator at the fresh air intake

## P: Heat recovery wheel

0000 - Without optional accessories  
Unused  
A: Wheel speed with on/off control  
B: Wheel speed with variable control  
A: Channel spacing of 2,0 mm  
B: Channel spacing of 2,5 mm  
A: Material: Aluminium  
B: Material: Aluminium with epoxy  
C: Material: Hybrid wheel  
D: Material: aluminium with silicagel

## Q: Extra heating

O: Without extra heating  
B: Heat recovery coil  
C: Preheater (electrical coil) in fresh air (N)  
D: Preheater (electrical coil) in fresh air (F)

## R: Special applications

O: Without special applications  
B: Active dehumidification condensation coil  
C: Air zoning  
D: Low return temperature application  
I: Low T application + Air zoning  
K: Low T application + Active dehumidification  
L: 100% fresh air  
M: 100% fresh air + Air zoning

## S: Sensors

0000 - Without options  
A: Smoke detection control unit  
A: CO<sub>2</sub> sensor environment installation  
B: CO<sub>2</sub> sensor ducted installation  
C: CO<sub>2</sub> sensor on the pLAN network  
A: 1 sensor RS485  
B: 2 sensors RS485  
C: 3 sensors RS485  
D: 4 sensors RS485  
E: 1 sensor NTC

A: Ambient temperature sensor  
B: Ambient temperature+humidity sensor  
C: Ambient sensor on the pLAN network

## T: Economizer management + Outdoor hum.

00 - Without economizer + without sensor  
A: Outdoor humidity sensor on the unit  
B: Outdoor hum. sensor on pLAN network  
A: Thermal management  
B: Thermoenthalpic management  
C: Enthalpic management

## U: Terminal + Unit communication

000 - Without terminal + stand-alone unit + without communication card  
A: Card RS485 Modbus/Carel  
B: Card Ethernet PCoWeb  
C: Card RS485 LonWorks®  
D: Card Ethernet BACnet™  
E: Card RS485 BACnet™  
F: Card RS485 Konnex  
0: Stand-alone unit  
A: Master unit  
B: Slave unit  
A: Graphic terminal in electrical cabinet  
B: User terminal in electrical cabinet  
C: Graphic terminal in the cabinet + User terminal remote up to 100 m  
D: User terminal in the cabinet + Graphic terminal remote up to 200 m  
E: Graphic terminal in the cabinet + Graphic terminal remote up to 200 m  
F: Touch panel in electrical cabinet  
G: Touch panel in the cabinet + Graphic terminal remote up to 200 m  
H: Touch panel in the cabinet + User terminal remote up to 100 m

## V: Miscellaneous item 1

000 - Without options  
A: On-off control of an humidifier  
B: Proportional control of an humidifier  
A: Electrical energy meter  
B: Cooling capacity & elec. energy meter  
A: Refrigerant leak detector

## W: Miscellaneous item 2

AA00 - Switching devices + std phase relay  
A: Compressor soft starter  
A: Varnish protection  
Unused  
Unused

## X: Return fan

0000 - Without return fan  
A: Centrif., low flow and nominal pressure  
B: Centrif., low flow and high pressure  
C: Centrif., nominal flow and nominal press.  
D: Centrif., nominal flow and high pressure  
E: Centrif., high flow and nominal pressure  
F: Centrif., high flow and high pressure  
G: Centrif., low flow and low pressure  
H: Centrif., nominal flow and low pressure  
I: Centrif., high flow and low pressure  
M: Plug-fan, nominal pressure (aluminium)  
Unused

## Y: Indoor air direction

0000 - Lower direction  
0: Lower supply and lower return  
1: Lateral supply and lower return  
2: Lower supply and lateral return  
3: Lateral supply and lateral return  
4: Upper supply and lower return  
5: Lateral supply and upper return  
6: Upper supply and lateral return  
7: Lower supply and upper return  
8: Upper supply and upper return  
Unused

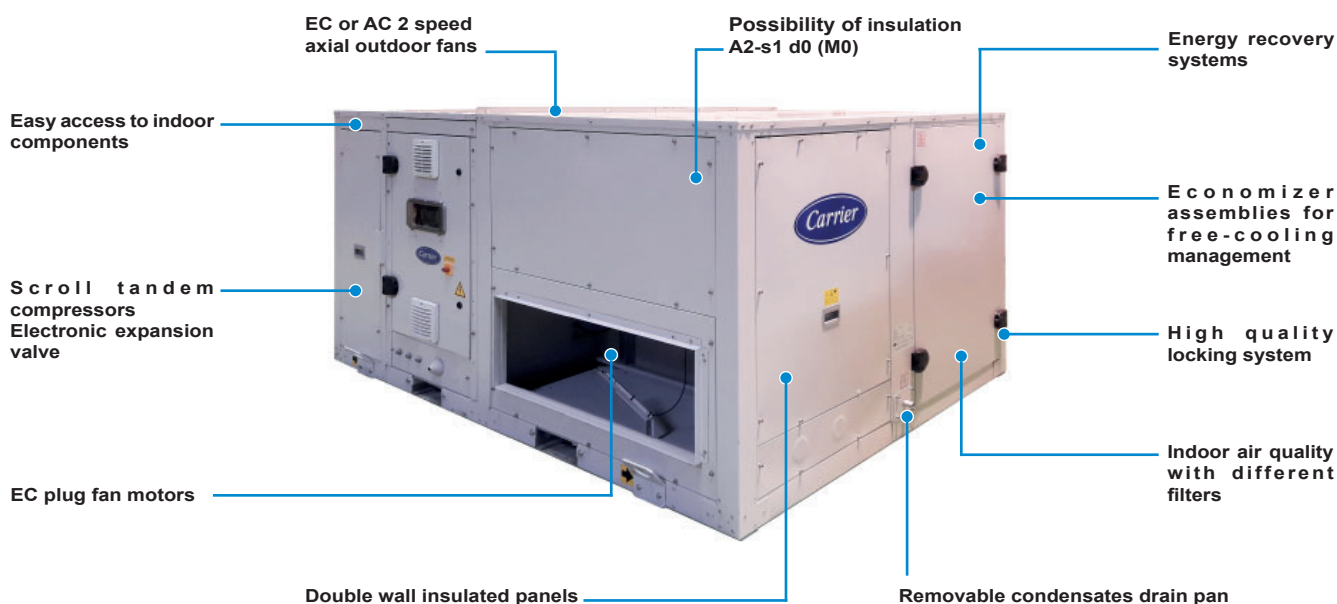

## UNIT COMPONENTS

### Casing

- New self-supporting frame that allow the transport of two stacked units and without the need for a wooden pallet.
- Casing made of galvanised steel metal, most parts protected with polyester paint, white colour RAL 7035.
- Removable panels for easy access to all components: electrical cabinet, compressors, fans, filters, etc.

### Outdoor circuit

- Coil with copper pipes and aluminium fins.
- EC electronic axial fan(s) which adapt the rotation speed to the installation's requirements, thereby reducing electricity consumption, the sound level at partial charge and improving the unit's average seasonal efficiency.

The cover with the motor fan(s) may be lifted to access the inside of the outdoor circuit.

### Indoor circuit

- Thermal and acoustic insulation, in double wall panels and registers, with Euroclass A2-s1, d0 (M0) fire classification.
- Coil with copper pipes and aluminium fins.
- Two configurations are available, depending on the indoor air flow direction:
  - "Standard" (all models: 50FF 020 to 093 and 50FC 020 to 099)
  - "In-line" (models 50FF/FC 052 to 093).

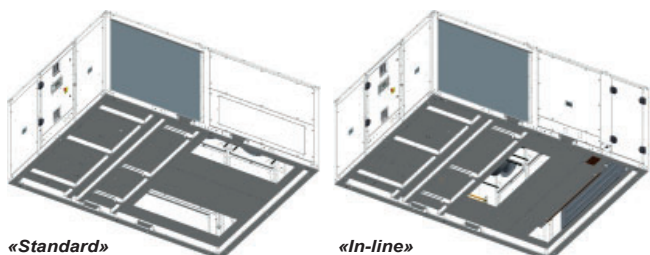

- EC electronic supply plug-fans with variable control speed and flow rate controller.
- Reusable gravimetric air filters G4, mounted on a frame. Dual locking system mounted on the access panel to filters.
- Isolated pan of condensate drainage sloping down towards the drain. This pan is removable for easy cleaning.

### Cooling circuit

- Hermetic scroll-type compressors in tandem design, with intermediate discharge valve, that improves the management of stages and the part load efficiencies, assembled over antivibration mounts. Relay for phase-sequence monitoring and phase loss protection.
- Crankcase heater.
- Electronic expansion valve(s).
- Four-way cycle reversing valve(s) (heat pump units).
- Acid-resistant filter(s) dryer.
- Cooling design with:
  - 1-air volume: models 50FC 020 to 047 and models 50FF 020 to 093.
  - 2-air volumes: models 50FC 052 to 099.

### Protections

- High pressure pressostat(s).
- High and low pressure transducers.
- Refrigerant leak control (by low-pressure alarm).
- Compressor discharge temperature control.
- Main door switch.
- Protection for power lines of compressors with manual motor starters and power lines of fan motors with magnetothermic switches. These devices provide protection against overload, short circuit, phase failure and undervoltage.
- Automatic switch in the control circuit.

## UNIT COMPONENTS

### Electrical cabinet

- Complete and fully wired electrical cabinet. Insulated access door to prevent condensation. Forced ventilation of the electrical cabinet. Protection IP54.
- Numeration of wired and identification of components in the electrical cabinet. It permits easy tracing and diagnostics.
- Hinges + quarter-turn latches on the removable access door.
- Electrical power supply with neutral.
- Main ground connection.
- Compressor and fan motor contacts.

### “50FC” control

Factory-installed “50FC” control provide the capability for free standing operation or may be linked with a more extensive system. Factory-installed and programmed Modbus communication capability provides simple integration with the building BMS system.

The 50FF/FC range may also be configured to communicate via LonWorks®, BACnet™ MSTP, Konnex, Modbus TCP/IP, BACnet™ Ethernet, TCP/IP, SNMP V1-2-3, FTP y HTTP protocols, if required by the application.

The “50FC” control also have the capability to communicate with our supervision solutions: **pCO Web** (1 unit), **BOSS mini** (50 units) and **BOSS** (300 units).

This communication flexibility allows simple system integration, as well as data collection, trending, monitoring and alarm displays. The control provides unparalleled service diagnostic information.

With this control it is also possible to connect to a local pLAN (Local Area Network) for a maximum of 15 units, with one unit configured as “Master” and the others as “Slaves”. This network allows the exchange of data and information between the units, and depending on the conditions of the installation, share the reading of some probes installed on the unit configured as “Master”, temperature setpoints and operating mode. It is also possible to configure one unit as “Back-up” just in case for failure of the another unit on the pLAN network.

The “50FC” control are your link to a world of simple and easy-to-use rooftop units that offer outstanding performance and value. With the sensors, it maintains control over all the components of the unit and helps optimise the performance of the refrigeration circuits as conditions change, resulting in the following features:

- Higher part load efficiency.
- Better control of temperature.
- Superior reliability.
- High ambient cooling operation at 48°C.
- Low ambient cooling operation at -15°C WB.

The main functions of this control are:

- Selection of setpoint and operating mode: HEATING / COOLING / AUTO / VENTILATION.
- Continuous control of the operating parameters.
- Display of the values measured by the sensors.
- Compressors cycles.
- Defrosting management.
- Control of the supply air temperature.
- All-seasons operation via the condensation and

evaporation pressure control.

The management of the unit in cooling mode is based on the principle of a high floating pressure. The condensation pressure setpoint is continually calculated depending on the outdoor temperature. This pressure is regulated by adjusting the air flow on the outdoor fans.

- Setpoint compensation based on the outdoor temperature.
- Hourly and weekly schedule.
- Fire protection.
- Diagnosis of faults and general alarm.
- Management of all the optional components available for the unit: economizer, back-up heating, CO<sub>2</sub> air quality sensor, energy recovery,...

### User interfaces

#### Graphic terminal

This terminal, fitted as standard on the electrical cabinet, is very easy to use. It provides detailed explanations of control in easy to understand English. No decoding is required.



Only 6, large, easy-to-use buttons are required to maneuver through the entire menus.

- This terminal is used to:
  - Carry out initial programming of the unit.
  - Modify operating parameters.
  - Switch the unit ON / OFF.
  - Select the operating mode and adjust the setpoints.
  - Display the variables controlled and sensor values measured.
  - Display the current alarms and their historical record.

#### User terminal (optional)

This terminal can be installed on the electrical cabinet, instead of the graphic terminal. In this case, the remote connection of the graphic terminal is possible.



- This terminal is used to:
  - Switch the unit ON / OFF.
  - Select the operating mode and adjust the setpoints.
  - Display the installation's temperatures and humidity, outdoor temperature, supply air temperature, CO<sub>2</sub> sensor and opening of the outdoor damper.
  - Display alarms codes.

#### Touch panel (optional)

With the same functions as the graphic terminal, the 4.3 inch touchscreen panel makes interaction between the user and the unit much easier by simplifying navigation between the various screens.



## PHYSICAL DATA WITH R-410A REFRIGERANT (EN-14511-2018)

50FF		020	028	037	040	045	047	052	058	062	070	074	086	093
<b>Cooling capacities</b>														
Cooling capacity (1)	kW	22,88	28,86	34,80	38,76	43,36	44,98	49,85	54,22	59,89	68,70	72,77	80,84	90,39
Power input (2)	kW	7,13	9,30	10,62	12,10	14,10	14,87	15,58	17,27	19,92	21,48	22,89	26,34	30,06
EER performance		3,21	3,10	3,28	3,20	3,07	3,02	3,20	3,14	3,01	3,20	3,18	3,07	3,01
SEER		4,89	4,84	4,59	4,44	4,33	4,32	4,63	4,55	4,49	4,49	4,49	4,31	4,25
ηs		193%	191%	181%	175%	170%	170%	182%	179%	177%	176%	177%	170%	167%
<b>Outdoor circuit fan</b>														
Electronic axial fan														
Nominal air flow	m <sup>3</sup> /h	9.000	14.500	17.000	17.000	17.000	17.750	31.000	31.000	31.000	33.000	33.000	34.500	35.000
Available static pressure	mm.w.c	5												
Number / Diameter	mm	1 / 630	1 / 800					2 / 800						
Ingress protection rating		IP54	IP55					IP55						
Maximum speed	r.p.m.	1.140	1.020					1.020						
Motor output	kW	0,9	2,6					2 x 2,6						
Maximum absorbed current	A	1,6	3,9					7,8						
<b>Indoor circuit supply fan</b>														
Electronic plug-fan														
Nominal air flow	m <sup>3</sup> /h	5.100	6.500	8.500	8.750	9.000	9.000	12.000	12.500	12.500	15.500	15.500	16.000	16.000
Available static pressure	mm.w.c	12	12	12	15	15	15	20	20	20	20	20	20	25
Number / Diameter	mm	1 / 500	1 / 500					2 / 500					2 / 500	
Speed	r.p.m.	1.800	1.855					1.800					1.855	
Motor output	kW	1 x 3,1	1 x 3,1					2 x 3,1					2 x 3,1	
Maximum absorbed current	A	4,7	4,8					9,4					9,6	
<b>Compressor</b>														
Scroll														
No. compressors / stages / circuits		2 / 2 / 1												
Oil type		Copeland 3MAF 32cST, Danfoss POE 160SZ, ICI Emkarate RL 32CF, Mobil EAL Artic 22CC												
Volume of oil	l	2,5	2,5	3,3	3,5	3,5	3,5	3,6	5,0	5,0	5,0	6,5	6,8	6,8
<b>Electrical characteristics</b>														
Mains voltage		400 V / III ph / 50 Hz (±10%)												
Power supply		3 Wires + Ground + Neutral												
Maximum absorbed current	A	19,8	27,4	29,0	32,8	37,0	37,4	46,8	48,4	59,2	59,2	64,8	67,7	80,2
<b>Refrigerant</b>														
R-410A														
Global warming potential (3)	GWP	2.088												
Charge	kg	7,3	7,6	9,7	9,7	10,0	10,3	9,7	9,7	10,0	17,0	17,5	17,5	18,0
Environment impact	tCO <sub>2</sub> eq	15,2	15,9	20,3	20,3	20,9	21,5	20,3	20,3	20,9	27,1	28,2	28,2	29,2
Additional charge of optional active dehumid.	kg	3,3	3,3	5,4	5,4	5,4	5,4	10,5	10,5	10,5	10,5	10,5	10,5	10,5
Environment impact of optional active dehumid.	tCO <sub>2</sub> eq	6,9	6,9	11,3	11,3	11,3	11,3	21,9	21,9	21,9	21,9	21,9	21,9	21,9
<b>Weight</b>														
B1 assembly	kg	594	617	699	698	704	701	914	929	936	1.035	1.059	1.057	1.078

- (1) Cooling capacity calculated in accordance with the EN-14511-2018 standard given for indoor temperature conditions 27°C, 19°C WB and 35°C outdoor temperature.  
(2) Total power input by compressors and motorised fans under nominal conditions, calculated in accordance with the EN-14511-2018 standard.  
(3) Climatic warming potential of a kilogram of fluorinated greenhouse gas in relation to a kilogram of carbon dioxide over a period of 100 years.

### Compliance

- Machinery Directive 2006/42/EC (MD)
- Electromagnetic Compatibility Directive 2014/30/EU (EMC)
- Pressure Equipment Directive 2014/68/EU (Category 2) (PED)
- RoHS Directive 2011/65/EU (RoHS)
- Eco-design Directive 2009/125/EC (ECO-DESIGN)
- Energy Labelling Directive 2017/1369/EU (ECO-LABELLING)
- Harmonised Standard: EN 378-2:2012 (Refrigerating systems and heat pumps - Safety and environmental requirements).



Eurovent  
certified  
values

# PHYSICAL DATA WITH R-410A REFRIGERANT (EN-14511-2018)

50FC		020	028	037	040	045	047	052	058	062	070	074	086	093	099
<b>Cooling capacities</b>															
Cooling capacity (1)	kW	22,31	27,78	33,44	36,90	41,50	43,92	53,22	57,80	60,39	68,26	72,22	80,66	90,18	96,95
Power input (3)	kW	7,00	8,98	10,25	11,79	13,40	14,26	16,53	18,38	19,38	21,27	22,89	25,77	28,94	36,49
EER performance		3,19	3,09	3,26	3,13	3,10	3,08	3,22	3,14	3,12	3,21	3,15	3,13	3,12	2,66
SEER		4,82	4,83	4,57	4,44	4,34	4,35	4,82	4,82	4,85	4,62	4,56	4,44	4,45	4,28
ηs		190%	190%	180%	175%	171%	171%	190%	190%	191%	182%	179%	175%	175%	168%
<b>Heating capacities</b>															
Heating capacity (2)	kW	21,88	27,72	33,05	36,61	41,82	44,56	50,71	55,79	58,57	67,68	71,77	80,38	89,66	99,61
Power input (3)	kW	5,82	7,99	9,09	10,21	12,00	12,95	14,43	16,01	16,89	18,97	20,27	22,91	25,90	31,32
COP performance		3,76	3,47	3,64	3,59	3,49	3,44	3,51	3,48	3,47	3,57	3,54	3,51	3,46	3,18
SCOP		3,47	3,43	3,45	3,45	3,46	3,44	3,57	3,59	3,50	3,49	3,55	3,59	3,58	3,25
ηs		136%	134%	135%	135%	135%	135%	140%	141%	137%	137%	139%	141%	140%	127%
<b>Outdoor circuit fan</b>															
Electronic axial fan															
Nominal air flow	m³/h	9.000	14.500	17.000	17.000	17.000	17.750	31.000	31.000	31.000	33.000	33.000	34.500	35.000	39.500
Available static pressure	mm.w.c	5													
Number / Diameter	mm	1 / 630	1 / 800				2 / 800								
Ingress protection rating		IP54	IP55				IP55								
Maximum speed	r.p.m.	1.140	1.020				1.020								
Motor output	kW	0,9	2,6				2 x 2,6								
Maximum absorbed current	A	1,6	3,9				7,8								
<b>Indoor circuit supply fan</b>															
Electronic plug-fan															
Nominal air flow	m³/h	5.100	6.500	8.500	8.750	9.000	9.000	12.000	12.500	12.500	15.500	15.500	16.000	16.000	18.000
Available static pressure	mm.w.c	12	12	12	15	15	15	20	20	20	20	20	20	25	25
Number / Diameter	mm	1 / 500	1 / 500				2 / 500								
Speed	r.p.m.	1.800	1.855				1.800								
Motor output	kW	1 x 3,1	1 x 3,1				2 x 3,1								
Maximum absorbed current	A	4,7	4,8				9,4								
<b>Compressor</b>															
Scroll															
No. compressors / stages / circuits		2 / 2 / 1						4 / 4 / 2							
Oil type		Copeland 3MAF 32cST, Danfoss POE 160SZ, ICI Emkarate RL 32CF, Mobil EAL Artic 22CC													
Volume of oil	l	2,5	2,5	3,3	3,5	3,5	3,5	2,5 + 2,5	2,5 + 2,5	2,5 + 3,3	3,3 + 3,3	3,3 + 3,5	3,5 + 3,5	3,5 + 3,5	5,0 + 5,0
<b>Electrical characteristics</b>															
Mains voltage		400 V / III ph / 50 Hz (±10%)													
Power supply		3 Wires + Ground + Neutral													
Maximum absorbed current	A	19,8	27,4	29,0	32,8	37,0	37,4	49,5	54,8	56,3	57,8	61,6	69,8	74,8	78,0
<b>Refrigerant</b>															
R-410A															
Global warming potential (4)	GWP	2.088													
Charge	kg	8,0	8,3	11,0	11,0	11,3	11,6	2 x 6,3	2 x 6,4	2 x 6,5	2 x 10,0	2 x 10,2	2 x 10,2	2 x 10,3	11,0 + 11,4
Environment impact	tCO2eq	16,7	17,3	23,0	23,0	23,6	24,2	26,1	26,7	27,1	41,8	42,4	42,4	42,8	46,8
Additional charge of optional active dehumid. (5)	kg	4,9	4,9	4,6	4,6	4,6	4,6	11,2	11,2	11,2	11,5	11,5	11,5	11,5	--
Environment impact of optional active dehumid.	tCO2eq	10,2	10,2	9,6	9,6	9,6	9,6	23,4	23,4	23,4	24,0	24,0	24,0	24,0	--
<b>Weight</b>															
B1 assembly	kg	594	617	699	698	704	701	986	986	1.004	1.146	1.146	1.135	1.160	1.186

- (1) Cooling capacity calculated in accordance with the EN-14511-2018 standard given for indoor temperature conditions 27°C, 19°C WB and 35°C outdoor temperature.
- (2) Heating capacity calculated in accordance with the EN-14511-2018 standard given for indoor temperature conditions 20°C and 6°C WB outdoor temperature.
- (3) Total power input by compressors and motorised fans under nominal conditions, calculated in accordance with the EN-14511-2018 standard.
- (4) Climatic warming potential of a kilogram of fluorinated greenhouse gas in relation to a kilogram of carbon dioxide over a period of 100 years.
- (5) In two-circuit models, additional charge on circuit 2.

## Compliance

- Machinery Directive 2006/42/EC (MD)
- Electromagnetic Compatibility Directive 2014/30/EU (EMC)
- Pressure Equipment Directive 2014/68/EU (Category 2) (PED)
- RoHS Directive 2011/65/EU (RoHS)
- Eco-design Directive 2009/125/EC (ECO-DESIGN)
- Energy Labelling Directive 2017/1369/EU (ECO-LABELLING)
- Harmonised Standard: EN 378-2:2012 (Refrigerating systems and heat pumps - Safety and environmental requirements).



Eurovent certified values

# ECODESIGN REGULATIONS

## New metrics because seasonal efficiency matters

With all new buildings expected to be close to zero energy, calculations of the energy efficiency of buildings require accurate indicators of the efficiency of their equipment. These indicators must be representative of actual operations throughout the year, measuring the performance of equipment on a seasonal basis.

**EER & COP belong to the past.** Now, and in the future, the focus is on seasonal efficiency. With a broad new products range, Carrier is fully engaged to take up the challenge of energy efficiency.

**Compliance with the Ecodesign regulations therefore involves the use of new, more meaningful seasonal efficiency metrics.** The Seasonal Energy Efficiency Ratio (SEER), and Seasonal Coefficient of Performance (SCOP) all ensure precise evaluation of the energy actually consumed by rooftops, by including seasonal variations in their measurements. Previous metrics (EER & COP) measured operations only at a single point, at full thermal load, and were therefore less representative of consumption over entire heating and cooling seasons.

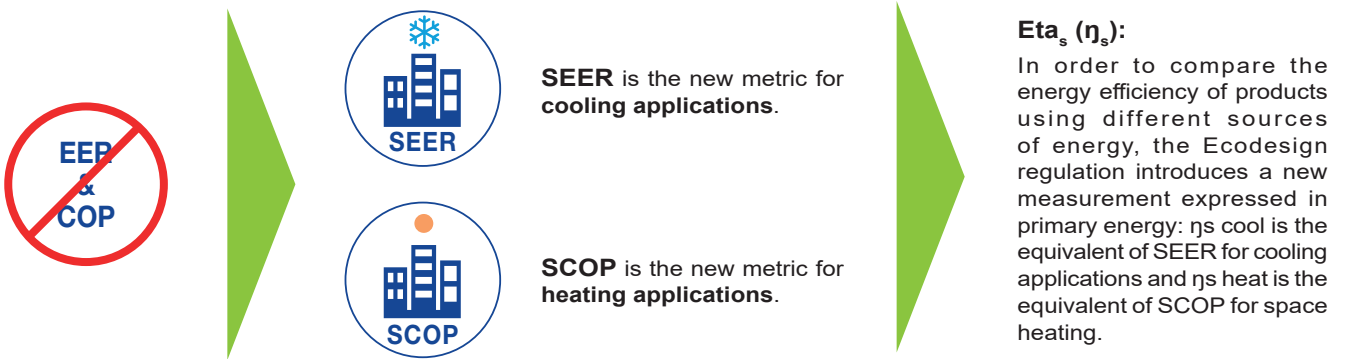

These new seasonal performance metrics are now the key indicator used for rooftops, in all applications. They are calculated according to technical standard **EN 14825** and compliance is mandatory for a product to obtain CE marking.

### Confort cooling

#### SEER - Seasonal Energy Efficiency Ratio



SEER measures the seasonal energy efficiency of rooftops by calculating the ratio between annual cooling demand and annual energy input. It takes into account the energy efficiency achieved for each outdoor temperature weighted by the number of hours observed for each of these temperatures, using actual climate data.

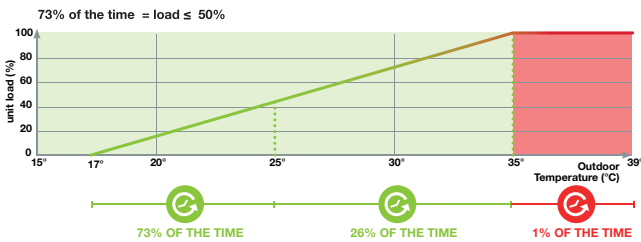

SEER is a new way of measuring the true energy efficiency of rooftops for cooling over an entire year.

This new indicator gives a more realistic indication of the real energy efficiency and environmental impact of a cooling system.

#### Efficiency requirements

Regulation 2016/2281 sets seasonal energy efficiency in Eta<sub>s</sub> cool (η<sub>s</sub> cool). This expresses SEER in terms of primary energy and so makes it possible to compare the energy efficiency of units using different energy sources.

Minimum η<sub>SC</sub> (SEER) according regulation (EU) 2016/2281:

From 01/2018. Tier1		From 01/2021. Tier2	
η <sub>SC</sub> %	SEER	η <sub>SC</sub> %	SEER
117	3,00	138	3,53

### Space heating

#### SCOP – Seasonal Coefficient of Performance



SCOP measures the seasonal energy efficiency of rooftops by calculating the ratio between annual heating demand and annual energy input. It takes into account the energy efficiency achieved at each outdoor temperature of an average climate weighted by the number of hours observed for each of these temperatures.

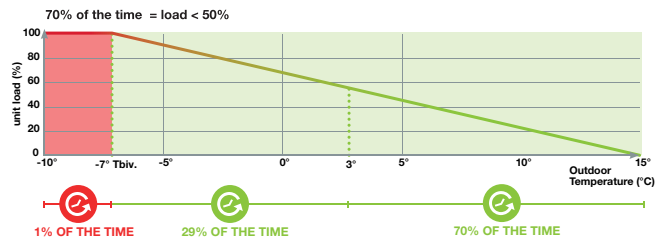

SCOP is a new way of measuring the true energy efficiency in heating mode over an entire year.

This new indicator gives a more realistic indication of the real energy efficiency and environmental impact of the heating system.

#### Efficiency requirements

Regulation 2016/2281 sets seasonal energy efficiency in Eta<sub>s</sub> heat (η<sub>s</sub> heat). This expresses SCOP in terms of primary energy and so makes it possible to compare the energy efficiency of units using different energy sources.

Minimum η<sub>SH</sub> (SCOP) according regulation (EU) 2016/2281:

From 01/2018. Tier1		From 01/2021. Tier2	
η <sub>SH</sub> %	SCOP	η <sub>SH</sub> %	SCOP
115	2,95	125	3,20

As stipulated in Annex II paragraph 5 of Regulation 2016/2281, the technical data sheets (TDS) for CARRIER units are available at <http://www.ecodesign.hvac.carrier.com/>









## OPERATING LIMITS

Inlet air conditions		Cooling		Inlet air conditions		Heating	
		50FF	50FC			50FC	
Indoor coil	Minimum temperature	9,7°C WB		Indoor coil	Minimum temperature	10°C	
	Maximum temperature	24°C WB			Maximum temperature	27°C	
Outdoor coil	Minimum temperature	-10°C (1)		Outdoor coil	Minimum temperature	-15°C WB (2)	
	Maximum temperature	52°C	48°C		Maximum temperature	15°C WB	

(1) With the condensation pressure control disabled, operation up to 12°C.

(2) When the outdoor temperature is usually below 5°C WB, the installation of a support element is recommended.

## SOUND LEVELS dB(A)

### Sound power level (LW)

50FF	020	028	037	040	045	047	052	058	062	070	074	086	093
63 Hz	55,2	60,8	61,4	60,9	61,3	63,1	64,3	64,5	64,9	64,8	64,6	64,6	65,3
125 Hz	64,2	66,7	68,9	66,1	70,0	71,1	69,6	69,9	71,5	72,4	71,3	71,4	74,0
250 Hz	71,8	74,8	76,1	72,9	76,3	76,4	77,0	77,7	78,9	79,7	78,4	77,9	79,3
500 Hz	70,2	76,7	76,4	76,8	77,1	78,3	79,5	80,1	80,4	79,9	80,1	80,2	80,9
1000 Hz	72,0	76,2	76,3	77,5	77,3	78,2	79,4	79,9	80,2	79,8	80,4	80,6	80,7
2000 Hz	69,7	73,5	74,3	75,3	74,1	75,5	77,0	77,4	77,8	77,7	78,3	78,1	77,7
4000 Hz	62,6	69,2	70,3	70,6	70,4	72,2	73,1	73,4	73,7	73,8	73,9	74,2	74,4
8000 Hz	59,0	63,7	65,5	65,8	65,6	67,5	67,9	68,2	68,6	68,9	69,1	69,4	69,6
Total dB(A)	77,5	82,0	82,5	82,5	83,0	84,0	85,0	85,5	86,0	86,0	86,0	86,0	86,5

50FC	020	028	037	040	045	047	052	058	062	070	074	086	093	099
63 Hz	55,2	60,8	61,4	60,9	61,3	63,1	64,3	64,5	64,9	64,8	64,6	64,6	65,3	66,8
125 Hz	64,2	66,7	68,9	66,1	70,0	71,1	69,6	69,9	71,5	72,4	71,3	71,4	74,0	75,5
250 Hz	71,8	74,8	76,1	72,9	76,3	76,4	77,0	77,7	78,9	79,7	78,4	77,9	79,3	80,8
500 Hz	70,2	76,7	76,4	76,8	77,1	78,3	79,5	80,1	80,4	79,9	80,1	80,2	80,9	82,4
1000 Hz	72,0	76,2	76,3	77,5	77,3	78,2	79,4	79,9	80,2	79,8	80,4	80,6	80,7	82,2
2000 Hz	69,7	73,5	74,3	75,3	74,1	75,5	77,0	77,4	77,8	77,7	78,3	78,1	77,7	79,2
4000 Hz	62,6	69,2	70,3	70,6	70,4	72,2	73,1	73,4	73,7	73,8	73,9	74,2	74,4	75,9
8000 Hz	59,0	63,7	65,5	65,8	65,6	67,5	67,9	68,2	68,6	68,9	69,1	69,4	69,6	71,1
Total dB(A)	77,5	82,0	82,5	82,5	83,0	84,0	85,0	85,5	86,0	86,0	86,0	86,0	86,5	88,0

### Sound pressure level (LP)

Measurement conditions: in a clear field, measured at a distance of 5 metres, directivity 2 and at 1,5 metres from the ground.

50FF	020	028	037	040	045	047	052	058	062	070	074	086	093
Total dB(A)	51,0	55,5	56,0	56,0	56,5	57,5	58,3	58,8	59,3	59,3	59,1	59,1	59,6

50FC	020	028	037	040	045	047	052	058	062	070	074	086	093	099
Total dB(A)	51,0	55,5	56,0	56,0	56,5	57,5	58,3	58,8	59,3	59,3	59,1	59,1	59,6	61,1

Note: The sound pressure level depends on the installation conditions and, as such, it only indicated as a guide. Values obtained according to the ISO 3744 standard.

# FACTORY OPTIONS AND ACCESSORIES

Category	Description	Factory installed option	Field installed accessory	Models
Electrical power	400 V / 3 ph / 50 (without neutral)	X		All
Flow + Assembly	B2: Standard. Economizer, 2 dampers	X		All
	BF: Standard. 100% fresh air	X		All
	B3: Standard. Economizer, 3 dampers	X (*)		All
	BX: Standard. Axial fan in return section	X (*)		All
	BP: Standard. Plug-fan in return section	X (*)		All
	BA: Standard. Cooling recovery circuit with plug-fan in return section	X (*)		All
	BT: Standard. Return top box with plug-fan or centrifugal fan	X		All
	BB: Standard. Cooling recovery circuit with plug-fan or centrifugal fan in return top box	X		All
	BW: Standard. Plug-fan in return section and heat recovery wheel module	X (*)		All
	BL: Standard. Return top box with plug-fan or centrif. fan and heat recovery module (upon request)	X (*)		All
	R2: In-line. Economizer, 2 dampers	X		052 to 093
	RP: In-line. EC plug-fan in return section	X (*)		052 to 093
	RW: In-line. Heat recovery wheel module	X (*)		052 to 093
	Coil coating	INERA® coils with aluminium alloy fins and copper pipes	X	
Coils with polyurethane pre-coated aluminium fins and copper pipes		X		All
Blygold® coating		X		All
Heating	Auxiliary hot water coil : Standard or Very low outdoor temperature	X		All
	Auxiliary electrical heaters	X		All
	Warm air heater module with gas burner (supplied installed inside a pre-assembly roofcurb)		X	All
	Gas-fired condensing boiler with hot water coil	X (*)		All
Protection low temperature	Freeze protection OAT lower than -10°C	X		All
	Freeze protection OAT lower than -14°C	X		All
	Freeze protection OAT lower than -10°C + spring shut-off dampers	X		All
	Freeze protection OAT lower than -14°C + spring shut-off dampers	X		All
Supply fan	Indoor plug-fan with nominal available pressure (Aluminum), low pressure or high pressure	X		All
Air filtration + droplet eliminator	Droplet eliminator after the indoor air coil	X	X	All
	Low pressure drop G4 filters	X	X	All
	G4 filters + M6, F7 or F9 folded filters	X	X	All
	Low pressure drop G4 filters + F7 or F9 folded filters	X	X	All
	Double stage of folded filters: M6+F7, M6+F9, F7+F9 or F9+F9	X	X	All
Outdoor fan	Two-speed direct-driven axial fans	X		All
Insulation	Thermal and acoustic insulation, Euroclass A2-s1, d0 (M0), in ceramic fibre	X		All
Indoor circuit	Condensates drain pan in stainless steel	X	X	All
	Room overpressure management	X		All
	Filter fouling detection with differential pressure switch	X		All
Outdoor circuit	Fresh air safety grid	X	X	All
	Outdoor coil protection grid	X	X	All
	Droplet eliminator at the fresh air intake	X	X	All
	Antivibration mounts made of rubber	X	X	All
Recovery wheel	Selection of the heat recovery wheel: materials, channel cross section, air filtration and speed control	X		All
Extra heating	Heat recovery coil	X (*)		All
	Preheater (electrical heater) in fresh air, low or nominal power		X	All
Special applications	Active dehumidification with condensation coil	X		020 to 093
	Air zoning	X (*)		All
	Low return temperature application	X		All
	Low return temperature application + Air zoning	X (*)		All
	Low return temperature application + Active dehumidification	X		020 to 093
Sensors	100% fresh air (without or with air zoning)	X		All
	NTC ambient temperature sensor on the control board or 1 to 4 sensors with RS485 communication	X	X	All
	Ambient temperature + humidity sensor with RS485 communication. Up to four sensors	X	X	All
	CO2 sensor: environment or ducted installation or installed on a pLAN network	X	X	All
	Smoke detection control unit in accordance with the NF S 61-961 standard	X	X	All
Economizer + Outd. humidity	Economizer management: thermal, enthalpic or thermoenthalpic	X	X	All
	Outdoor air humidity sensor: supplied with the unit or installed on a pLAN network	X	X	All
Terminal + Unit communication	Graphic terminal installed in the electrical cabinet + User terminal remote up to 100 m	X	X	All
	Graphic terminal installed in the electrical cabinet + Graphic terminal remote up to 200 m	X	X	All
	User terminal installed in the electrical cabinet	X	X	All
	User terminal installed in the electrical cabinet + Graphic terminal remote up to 200 m	X	X	All
	Touch panel in the electrical cabinet	X	X	All
	Touch panel in the cabinet + Graphic terminal remote up to 200 m	X	X	All
	Touch panel in the cabinet + User terminal remote up to 100 m	X	X	All
	Unit configuration: stand-alone, master or slave	X	X	All
	Communication cards: RS485 Modbus/Carel; Ethernet PCoWeb; RS485 LonWorks®; Ethernet BACnet™; RS485 BACnet™; RS485 Konnex	X	X	All
		X		All
Miscellaneous item 1	Management of an humidifier with on-off or proportional control	X		All
	Electrical energy meter	X		All
	Cooling capacity and electrical energy meter	X		All
	Refrigerant leak detector	X		All
Miscellaneous item 2	Compressor soft-starter	X		All
	Varnish protection for components on the electrical cabinet: control board, cards and terminals	X		All
Return fan	Centrifugal return fan (BB and BT assemblies). 9 combinations of air flow and available pressure	X		All
	Return plug-fan with nominal pressure (Aluminium)	X		All
Air direction	There are 9 combinations in the direction of airflow with: - Supply: lower, lateral and upper - Return: lower, lateral and upper	X		All
Roofcurb	Pre-assembly roofcurbs with adjustable height		X	"Standard"
	Adaptation roofcurbs for replacing units on renovation		X	All

(\*) Part of this option must be installed on-site.

# FACTORY OPTIONS AND ACCESSORIES

## Assembly + Indoor air flow direction

### B assemblies: "Standard" (all models: 50FF 020 to 093 and 50FC 020 to 099)

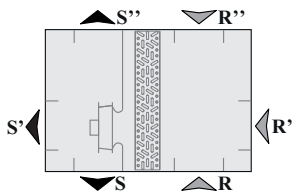
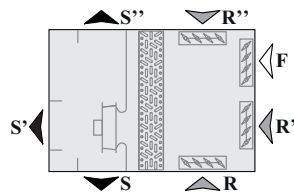
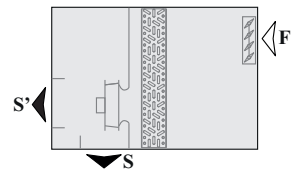
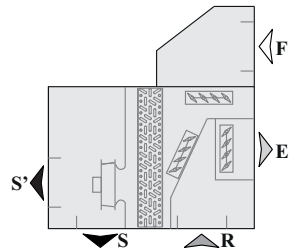
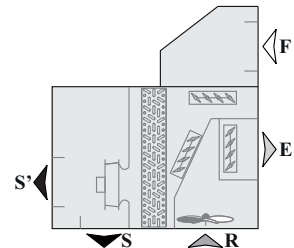
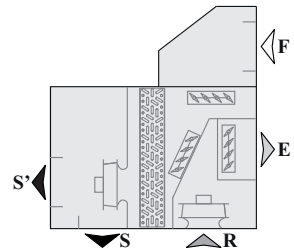
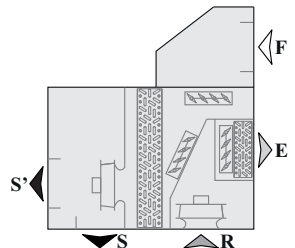
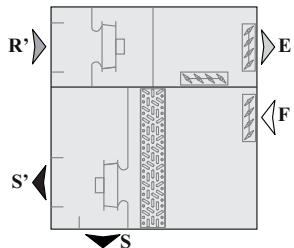
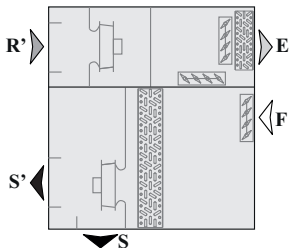
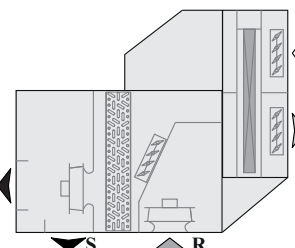
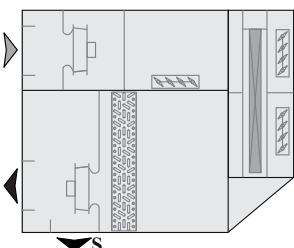
<p><b>B1 assembly</b> Standard</p> 	<p><b>B2 assembly</b> Economizer, 2 dampers: fresh air damper interlocked with return damper</p> 	<p><b>BF assembly</b> 100% fresh air</p> 								
<p><b>B3 assembly</b> Economizer, 3 dampers: fresh air damper and exhaust air damper</p> 	<p><b>BX assembly</b> Axial return fan</p> 	<p><b>BP assembly</b> Plug-fan in return section</p> 								
<p><b>BA assembly</b> Plug-fan in return section + Cooling recovery circuit (active recovery)</p> 	<p><b>BT assembly</b> Return top box with plug-fan or centrifugal fan</p> 	<p><b>BB assembly</b> Return top box with plug-fan or centrifugal fan + Cooling recovery circuit (active recovery)</p> 								
<p><b>BW assembly</b> Plug-fan in return section + Heat recovery wheel module (passive recovery)</p> 	<p><b>BL assembly (upon request)</b> Return top box with plug-fan or centrifugal fan + Heat recovery wheel module (passive recovery)</p> 	<p><b>Legend</b></p> <table border="1"> <tr> <td><b>S</b> Lower air supply</td> <td><b>R</b> Lower air return</td> </tr> <tr> <td><b>S'</b> Lateral air supply</td> <td><b>R'</b> Lateral air return</td> </tr> <tr> <td><b>S''</b> Upper air supply</td> <td><b>R''</b> Upper air return</td> </tr> <tr> <td><b>F</b> Fresh air intake</td> <td><b>E</b> Exhaust air outlet</td> </tr> </table> <p>Note: only one of the three possible options (lower, lateral or upper) can be selected for both, supply and return.</p>	<b>S</b> Lower air supply	<b>R</b> Lower air return	<b>S'</b> Lateral air supply	<b>R'</b> Lateral air return	<b>S''</b> Upper air supply	<b>R''</b> Upper air return	<b>F</b> Fresh air intake	<b>E</b> Exhaust air outlet
<b>S</b> Lower air supply	<b>R</b> Lower air return									
<b>S'</b> Lateral air supply	<b>R'</b> Lateral air return									
<b>S''</b> Upper air supply	<b>R''</b> Upper air return									
<b>F</b> Fresh air intake	<b>E</b> Exhaust air outlet									

Indoor airflow direction		
<b>0</b> Lower supply and lower return	<b>3</b> Lateral supply and lateral return	<b>6</b> Upper supply and lateral return
<b>1</b> Lateral supply and lower return	<b>4</b> Upper supply and lower return	<b>7</b> Lower supply and upper return
<b>2</b> Lower supply and lateral return	<b>5</b> Lateral supply and upper return	<b>8</b> Upper supply and upper return

# FACTORY OPTIONS AND ACCESSORIES

## Assembly + Indoor air flow direction

### R assemblies: "in-line" (models 50FF/FC 052 to 062)

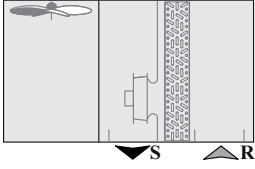
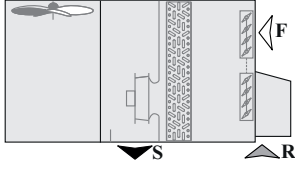
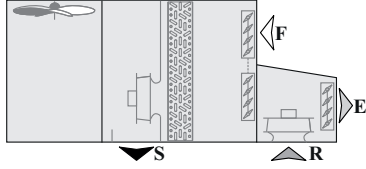
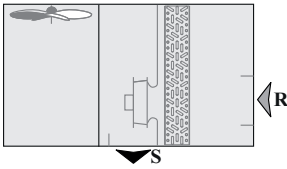
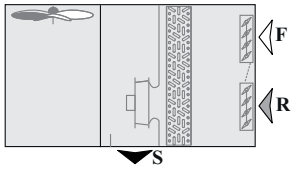
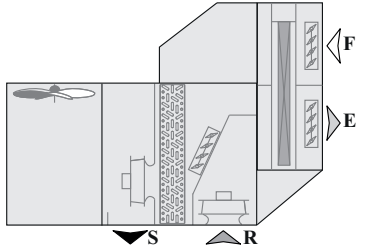
<p><b>R1 assembly, Direction 0</b></p> <p>"In-line" standard</p> 	<p><b>R2 assembly, Direction 0</b></p> <p>Economizer, 2 dampers: fresh air damper interlocked with return damper</p> 	<p><b>RP assembly, Direction 0</b></p> <p>Lower return plug-fan</p> 
<p><b>R1 assembly, Direction 2</b></p> <p>"In-line" standard</p> 	<p><b>R2 assembly, Direction 2</b></p> <p>Economizer, 2 dampers: fresh air damper interlocked with return damper</p> 	<p><b>RW assembly, Direction 0</b></p> <p>Lower return plug-fan + Rotary heat exchanger (passive recovery)</p> 

### R assemblies: "in-line" (models 50FF/FC 070 to 093)

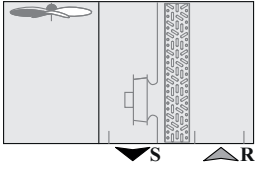
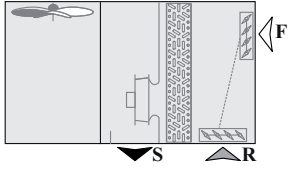
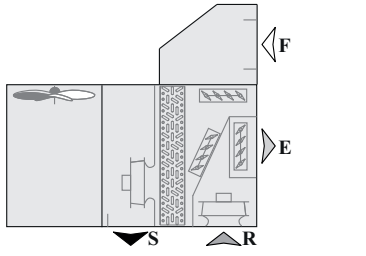
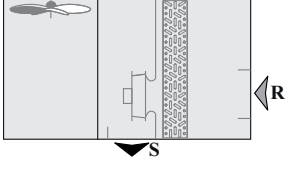
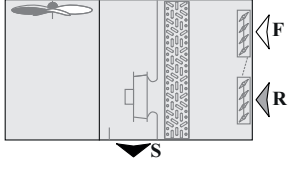
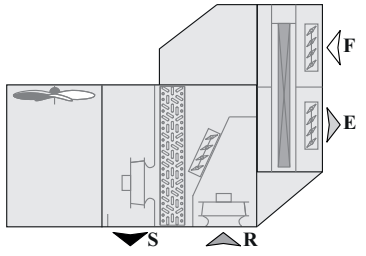
<p><b>R1 assembly, Direction 0</b></p> <p>"In-line" standard</p> 	<p><b>R2 assembly, Direction 0</b></p> <p>Economizer, 2 dampers: fresh air damper interlocked with return damper</p> 	<p><b>RP assembly, Direction 0</b></p> <p>Lower return plug-fan</p> 
<p><b>R1 assembly, Direction 2</b></p> <p>"In-line" standard</p> 	<p><b>R2 assembly, Direction 2</b></p> <p>Economizer, 2 dampers: fresh air damper interlocked with return damper</p> 	<p><b>RW assembly, Direction 0</b></p> <p>Lower return plug-fan + Rotary heat exchanger (passive recovery)</p> 

Indoor airflow direction	
<b>0</b>	Lower supply and lower return
<b>2</b>	Lower supply and lateral return

Leyenda					
<b>S</b>	Lower air supply	<b>R</b>	Lower air return	<b>F</b>	Fresh air intake
<b>S'</b>	Lateral air supply	<b>R'</b>	Lateral air return	<b>E</b>	Exhaust air outlet

# FACTORY OPTIONS AND ACCESSORIES

## Air pressure control in different assemblies

In case of assemblies with fresh air (ventilation) but without extraction air, overpressure will be generated in the building, higher with higher fresh air ratios or in free-cooling mode. It will not generate any issue in buildings with low air tightness and/or with doors frequently opened, but we should prevent in other applications. In assemblies with extraction damper and return fans, this overpressure can be completely avoided (pressure balance), or even controlled with a certain value to prevent infiltrations.

**50FF/FC** is the rooftop with the largest offer in airflow configurations to be able to adapt the unit to any kind of application or request. Please, find below comments and recommendations for each assembly.

Assembly		Fresh air and free-cooling	Return fans	Energy recovery (extraction)	Pressure control	Comments and recommendations
B1, R1		No	No	No	No control required	Only for building with <b>no need of fresh air</b> . Pressure balance by default. Same return and supply airflow.
B2, R2		Yes	No	No	No control	Adequate just for buildings with medium or low <b>air tightness</b> and/or doors frequently opened.
B2, R2 + gravity dampers in the building		Yes	No	No	High control	Building overpressure is maintained at the same level than pressure drop before the gravity damper. No limitations in the return pressure drop.
B3		Yes	No	No	Medium control	Recommended only with <b>low pressure drop in the return ductwork</b> (maximum 50 Pa). The maximum building overpressure is at the same level than pressure drop in the return ductwork.
BA, BB		Yes	Yes	Yes, Active recovery	High control	Return and supply EC plug-fan(s) are always supplied with pressure sensor to adjust the airflow. To manage <b>pressure balance</b> , supply and return are configured with same airflow.
BP, BT, RP		Yes	Yes	No	Total control	In case <b>overpressure</b> want to be managed (to avoid infiltration), the return airflow need to be lower than the supply. Differences <b>up to 10%</b> can be always being configured. Additional overpressure with airflow differences <b>up to 20%</b> are possible <b>adding the option "overpressure control"</b> (*) which manages fresh and exhaust dampers independently.
BW, RW		Yes	Yes	Yes, Passive recovery (wheel)	Total control	To maintain overpressure in case of variable fresh air management (with CO <sub>2</sub> sensor option), minimum fresh air ratio need to be configured.

(\*) This overpressure option is not available on BA and BB assemblies because this type of control of the dampers penalizes cooling recovery.

### Example:

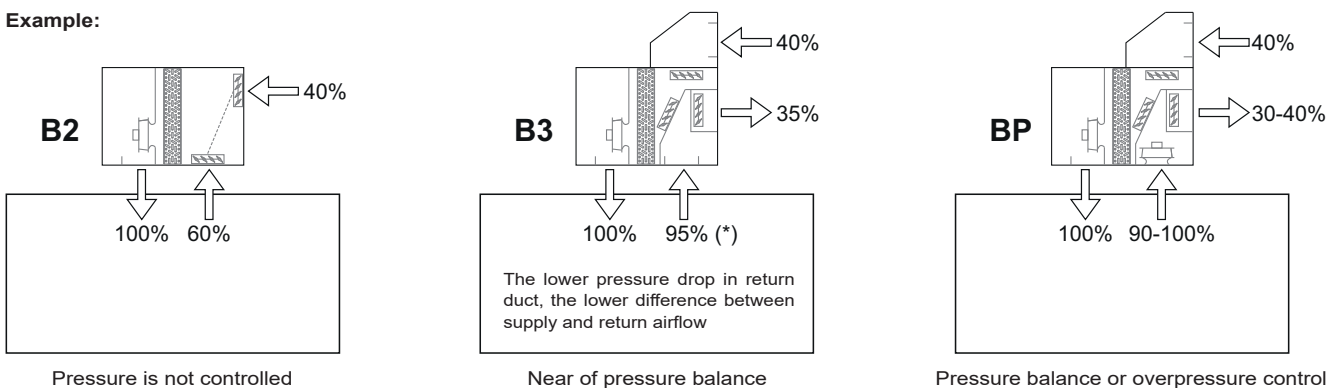



# FACTORY OPTIONS AND ACCESSORIES

## Electrical power

- These units can be supplied for the following power supply voltages:
  - 400 V / 3 ph + N / 50 Hz (standard)
  - 400 V / 3 ph / 50 Hz (optional)

## Coils coating

- Coils with copper pipes and aluminium fins with **polyurethane** coating.
 

Level of corrosion protection: basic. This treatment offers a resistance of more than 1000 hours (ASTM B117 NSST).
- Coils with copper pipes and fins of an aluminium alloy **INERA®**.
 

Level of corrosion protection: basic - medium. This treatment offers a resistance of more than 1000 hours (ASTM B117 NSST).
- **Blygold®** coating.
 

Level of corrosion protection: medium. This treatment offers more protection than 11000 hours in salt spray test (ASTM B117 NSST) and 4000 hours in acid salt spray test.

For further detailed information, please contact our Customer Service Department.

Note: These coating can be applied to various coils (outdoor, indoor and hot water coil) according to the combinations available in our "Selection Software".

## Heating

The unit only can incorporate one of these heating elements:

- **Auxiliary hot water coil**, with three-way valve and proportional control, for assembly inside the unit.
  - The unit incorporates a freeze protection thermostat.
  - There are two configuration types available:
    - Standard (HAS), with freeze protection thermostat.
    - Very low outdoor temperature (HAF), with freeze protection technology based on the water temperature. This protection is made up of a circulation pump as well as two sensors inserted in the input and the output of the coil.

Important: this option is mandatory for an outdoor temperature lower than -20°C WB. Consult for percentages of glycol water above 20%.

Note: on units with this option, air supply only may be lateral (factory-configured).

Note: the active dehumidification is not compatible with the hot water coil.

- **Auxiliary electrical heaters**, with two power stages and on/off control, for assembly and connection inside the unit.
 

Up to 3 values of total power available for each model:

50FF/FC	020 to 028	037 to 047	052 to 099
RAF (Low)	12 kW	12 kW	18 kW
RAM (Nominal)	18 kW	18 kW	27 kW
RAS (High)	unavailable	27 kW	36 kW

- Electrical heaters with proportional control (**upon request**).

- **Gas-fired condensing boiler with hot water coil.**

Natural or propane gas boiler with modulating actuator, in accordance with the Gas Directive 2009/142/EC, mounted on the side of the unit.

The boiler is connected to the water circuit of the auxiliary coil.

Up to 3 values of total power available for each model:

50FF/FC	020 to 047	052 to 099
BBF (Low)	unavailable	unavailable
BBM (Nominal)	unavailable	Condexa PRO 70
BBS (High)	Condexa PRO 70	Condexa PRO 100

Note: the active dehumidification is not compatible with the gas boiler.

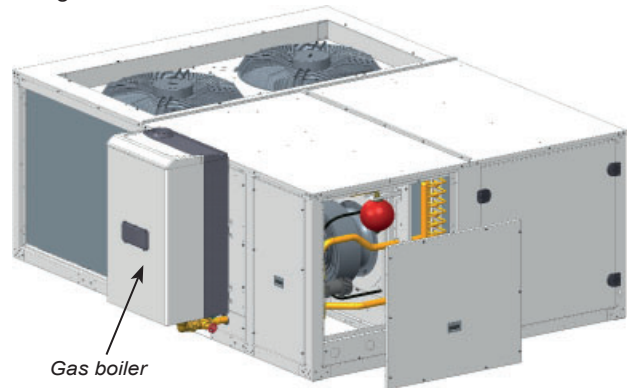

- **Warm air heater module with gas burner** with modulating actuator, in accordance with the Gas Directive 2009/142/EC, installed inside a pre-assembly roofcurb.

The 50FF/FC unit with lower air supply will be placed on this roofcurb.

Up to 3 values of total power available for each model:

50FF/FC	020 to 047	052 to 062	070 to 099
BAF (Low)	PCH020	unavailable	unavailable
BAM (Nominal)	PCH034	PCH065	PCH080
BAS (High)	PCH045	PCH080	PCH105

Note: It's recommended to use the filter fouling detector (optional) in units with gas burner.

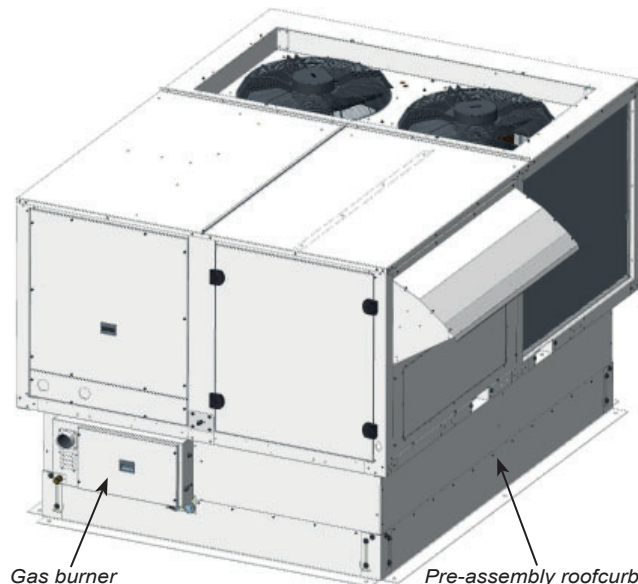

## FACTORY OPTIONS AND ACCESSORIES

### Protection for low outdoor temperature

- Freeze protection OAT lower than -10°C. Mandatory for an outdoor temperature lower than -10°C WB.
  - Electrical heater for protection of the components of the electrical cabinet.
  - Compressor with protection for low temperature.
- Freeze protection OAT lower than -14°C. Mandatory for an outdoor temperature lower than -14°C WB.

In addition to the options of -10°C, this includes:

  - Reinforced electrical heater for protection of the components of the electrical cabinet.
  - Electrical heater for anti-freeze protection of dampers of the economizer (if applicable).
  - Protective kit of the gas burner for low temperature (if applicable).
- Freeze protection OAT lower than -10°C + spring shut-off dampers in case of a power failure.
- Freeze protection OAT lower than -14°C + spring shut-off dampers in case of a power failure.

### Supply fan

- By default, these units are fitted with plug-fans for a nominal available pressure (N), in Polypropylene.

The following fans can optionally be supplied:

- F: Low available pressure: except for models 037, 040, 045, 047, 070 and 074.
- M: Nominal available pressure (Aluminium).
- S: High available pressure.

Note: Aluminium fans are rated A2-s1, d0 (M0) and comply with regulations for public promises in France.

Important: the "Selection Software" will choose the supply fan with lower consumption for the available pressure required.

### Air filtration + Droplet eliminator

Options to improve indoor air quality:

- Different combinations of filters are available:
  - Gravimetric filters G4 with low pressure drop.
  - Gravimetric filters G4 of standard type + folded opacimetric filters M6, F7 or F9.
  - Gravimetric filters G4 with low pressure drop + folded opacimetric filters F7 or F9.
  - Double-stage of folded opacimetric filters (M6+F7, M6+F9, F7+F9 or F9+F9).

Classification of these filters according to the new **ISO 16890 Standard**:

- G4 → ISO Coarse 60%
- M6 → ISO ePM10 70%
- F7 → ISO ePM1 50%
- F9 → ISO ePM1 80%

- Droplet eliminator after the indoor air coil. Recommended in cases where a high moisture content in the air is foreseen or when the air flow is high.

Note: with hot water coil it is not possible to assemble the droplet eliminator.

### Outdoor fan

- Two-speed direct-driven axial fan(s). Watertight motor class F, IP54 and internal thermal protection. Dynamically balanced propellers and outdoor protective grille.

Not recommended with the optional active dehumidification and outdoor temperatures below 12°C.

### Insulation

- Thermal and acoustic insulation in ceramic fibre, with Euroclass fire classification A2-s1, d0 (M0) in panels not removable in contact with the indoor air (top, bottom panel).

Note: the other panels and registers of the indoor circuit always include thermal and acoustic insulation, with Euroclass fire classification A2-s1, d0 (M0).

### Indoor circuit

- Condensate drain pan in stainless steel for corrosion protection.
- Room overpressure management. Assemblies that include a return fan allow the management of airflow differences between supply air and return air of up to 10%, setting up flow setpoints. Optionally, the fresh air damper and the exhaust damper can be managed independently for greater airflow differences. This option may be necessary to prevent the entry of outside air (BP, BT, BW, RP and RW assemblies).

Note: This option is not available on BA and BB assemblies because this type of control of the dampers penalizes cooling recovery.
- Filter fouling detection with differential pressure switch.

### Outdoor circuit

- Fresh air safety grid (9x9mm).
- Outdoor coil protection grid.
- Antivibration mounts made of rubber.
- Droplet eliminator at the fresh air intake. This one and the thermoenthalpic free-cooling are necessary in cases where a high moisture content in the air is foreseen.

### Heat recovery wheel

- The heat recovery wheel is fitted into a module placed on one side of the unit. This module is supplied disassembled with the unit, for installation on site.

Available with BW and RW assemblies, and upon request, with BL assembly.

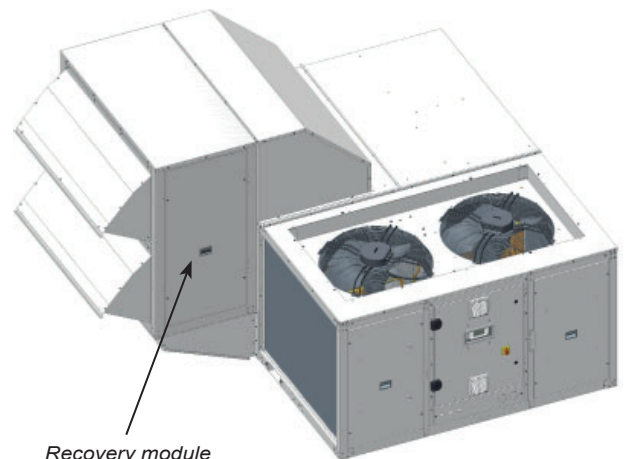

## FACTORY OPTIONS AND ACCESSORIES

This rotary recovery unit is used to transfer the sensible and latent heat from the air-conditioned room's return air to the fresh air used for ventilation, before it's discharged outdoors. This option reduces the compressors runtime, ensuring energy saving and benefiting the environment.

### Extra heating

■ **Heat recovery coil (HRC).** The coil function is to pre-heat the air that will pass through the main indoor coil. For this, it uses the temperature of an outdoor water installation.

The coil is supplied with a 3-way valve for installation outside the unit but manages by the electronic control.

This option is compatible with B1, B2, BF, BT, BB, R1 and R2 assemblies.

■ With BF assembly, 100% fresh air, it is possible to incorporate a **preheater module** (electrical heater) coupled to the fresh air intake. This module is supplied in kit for installation on site.

The electrical heater with proportional control will modulate capacity to get the condenser inlet conditions within the operating limits of the cooling circuit in case of very low outdoor temperatures.

Two values of power are available: low (F) and nominal (N).

Note: The electrical connection of the kit is the responsibility of the installer.

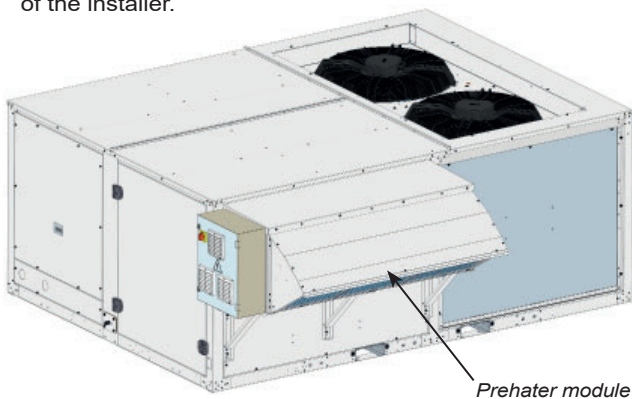

### Special applications

■ The mounting **100% fresh air** with no return or extraction air flow (BF assembly) will address special requests where return air flow cannot be used, in order to avoid contamination (kitchens, and some other places with indoor odours or other pollutants).

In order to keep the cooling circuit working inside operation limits, and depending on design conditions, the unit could be selected with lower air flow than minimum used for the same size in the rest of assemblies.

Depending on the heating design conditions, it is also necessary to select an additional electrical heating in the fresh air intake (preheater module).

■ **Active dehumidification with condensation coil.** Extra condensation coil for dehumidification applications in high relative humidity ambients.

This new option is the solution for applications which require the highest degree of indoor comfort and humidity control.

It could be of particular interest to the supermarkets, restaurants, museums and in cases of high latent cooling load and/or in humid climates.

It's used in low temperature stock applications to avoid condensation over goods or refrigeration cabinets glass doors.

It allows controlling the maximum levels of humidity in the room in the most efficient way, and independently of the location and the part-load of the unit.

Note: the active dehumidification is not compatible with the hot water coil, the gas boiler, the air zoning, the BF assembly and the 50FC 099 model.

### Operation of dehumidification

The dehumidification process is done by the main refrigerant coil. Hot gas recovered is injected in the additional condensation coil to reheat the air.

The use of the extra condensation coil to reheat the air after the evaporator provides a flexible and efficient operation to accurately compensate for the room demand.

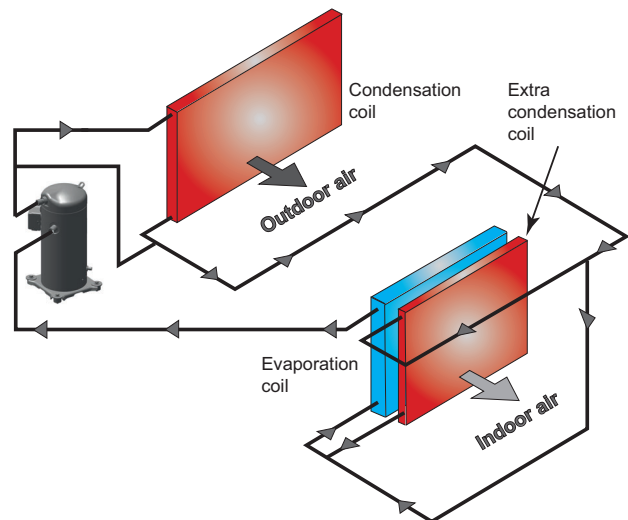

This option also allows an additional reheating using the auxiliary electrical heaters.

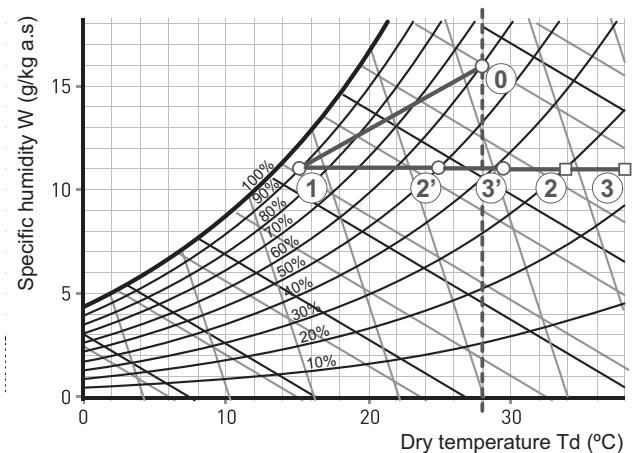

- 0 → 1: Normal evolution in the evaporator without using extra condensation coil
- 1 → 2: Reheating using extra condensation coil in units of 1 circuit
- 1 → 2': Reheating using extra condensation coil in units of 2 circuits
- 2 → 3: Additional reheating using the auxiliary electrical heaters in units of 1 circuit
- 2' → 3': Additional reheating using the auxiliary electrical heaters in units of 2 circuits

The "Selection software" allows to obtain the value of the supply air temperature for the point 2 (or 2') according to the extra condensation coil. It will also calculate point 3 (or 3') according to the power selected for the auxiliary electrical heaters.

## FACTORY OPTIONS AND ACCESSORIES

### Operational modes

Indoor conditions	Operational modes	
$T > T_c$ $H < H_c$		Cooling
$T > T_c$ $H > H_c$		Subcooling
$T < T_c$ $H > H_c$		Dehumidification + partial re-heat
$T < T_c$ $H > H_c$		Dehumidification + 100% re-heat
$T < T_c$ $H > H_c$		Dehumidification + 100% re-heat + auxiliary electrical heater (E.H.)
$T < T_c$ $H < H_c$		Heating

T: Ambient temperature  
Tc: Ambient temperature setpoint  
H: Ambient humidity  
Hc: Ambient humidity setpoint

### ■ Zoning of the air flow up to 4 different zones.

This option allows the management of the air flow of the unit to condition up to 4 different zones with a minimum air flow of 35% (all in one operating mode: heating or cooling). This function allows to adapt the indoor air flow to the installation requirements.

Note: zoning is only possible with plug-fans.

Regulation gives the control signal to the dampers installed in each zone (dampers and servomotors for those dampers not supplied). The unit modifies the air flow and capacity depending on information coming from sensors in each zone and considering active zones in each moment.

The option includes 4 zone terminals (one for each zone), the additional control board supplied in an independent box to be connected with the 4 terminals, the unit board and also to the servomotors that control dampers in each zone (dampers and servos not supplied).

The temperature information for each zone is coming from temperature sensor integrated inside each zone terminal. It is not needed to install any extra ambient sensor.

Note: In case the unit includes an economizer for enthalpy or thermoentropic free cooling (T+H control) an extra return T+H sensor in the offer is required. If the unit additionally includes CO<sub>2</sub> probe, it must be a return probe and not an ambient probe.

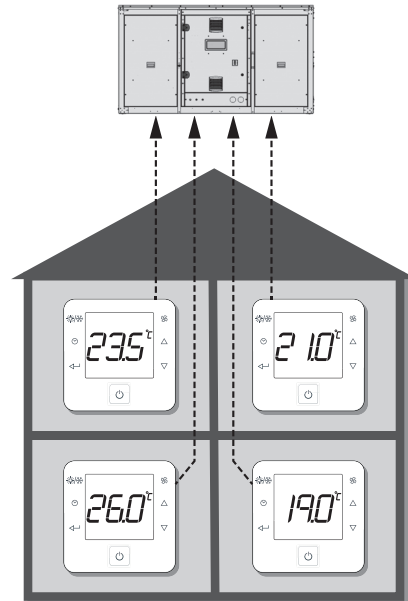

In following picture, electronic PCB and 4 zone terminals are detailed. Connections can be found in the "50FC" control manual.

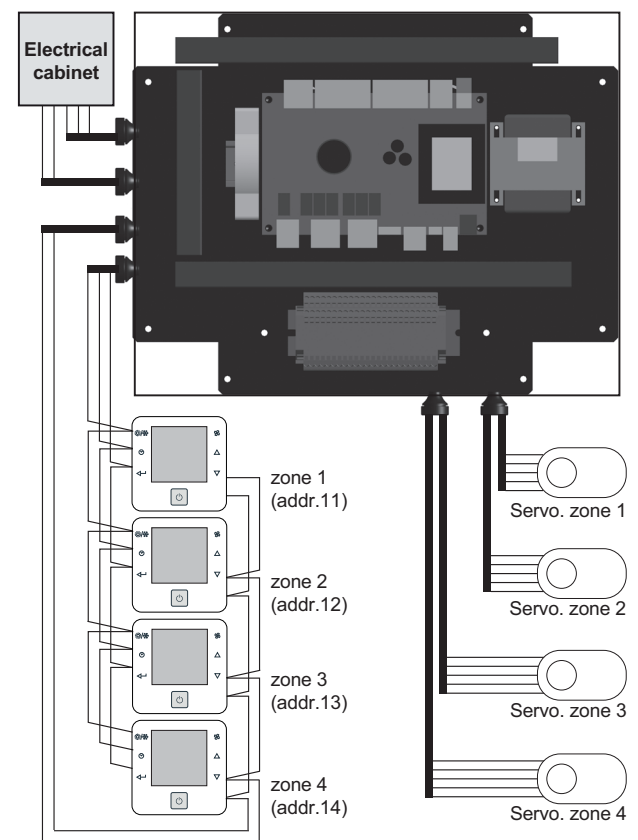

Note: There is a new option with **constant supply pressure** that extends the possibilities for multi-zone management. Available upon request.

Note: the active dehumidification is not compatible with the air zoning.

## FACTORY OPTIONS AND ACCESSORIES

■ **Low return temperature application.** This option is particularly interesting in certain applications for food conservation and it can be used in large storage facilities.

With this option, the unit adapts all its devices to manage low return temperature (15°C) in cooling mode. This is possible due to some changes in the control operation parameters.

The “Selection Software” includes the option as mandatory when return temperature is lower than 20°C (with 15°C as the minimum allowed value).

### Sensors

■ **Ambient temperature sensor(s).** There are 3 options:

- One NTC sensor connected to the control board.  
Note: An ambient sensor with RS485 communication is required for installation at more than 30 meters.
- Up to four sensors with RS485 communication.
- Sensor(s) installed on the master unit of the local network (pLAN).

■ **Ambient temperature + humidity sensor(s).** Up to four sensors with RS485 communication or installed on the pLAN network. This sensor is compulsory in units with enthalpic or thermoenthalpic free-cooling (optional). In this case, the outdoor air humidity sensor is also added.

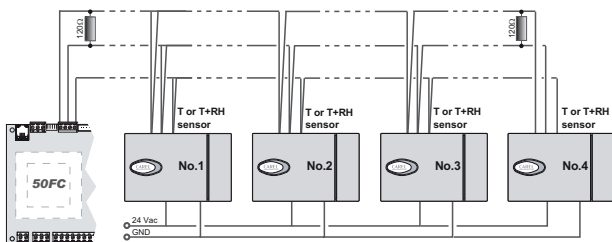

■ **CO<sub>2</sub> sensor for air quality control.** There are 3 options:

- Ambient air quality sensor,
- Return air quality sensor (duct-mounted),
- Sensor installed on the master unit of the local network (pLAN).

■ **Smoke detection** control unit in accordance with the NF S 61-961 standard, that uses a LED to indicate the installation status, and if the probe detects the presence of smoke in the installation, it stops the operation of the unit and gives the order to open or close the outdoor damper (configured by parameter).

To ensure compliance with the French regulations on Fire safety (ERP), it's possible to select the opening of the fresh air damper and the exhaust air damper to 100% (return air damper closed).

### Economizer management + outdoor humidity

■ The economizer allows to make best use of outdoor air conditions when these are more favourable than the return air conditions. This allows the cooling capacity to be reduced.

The percentage of outdoor air can vary between 0% and 100%.

The economizer management can be:

- Thermal, by comparing the temperatures.
- Enthalpic, by comparing the enthalpies. Recommended in cases where a high moisture content in the air is foreseen.
- Thermoenthalpic, by comparing the enthalpies and correcting for temperature. This is the optimum solution as it takes the variability of the climate into account.

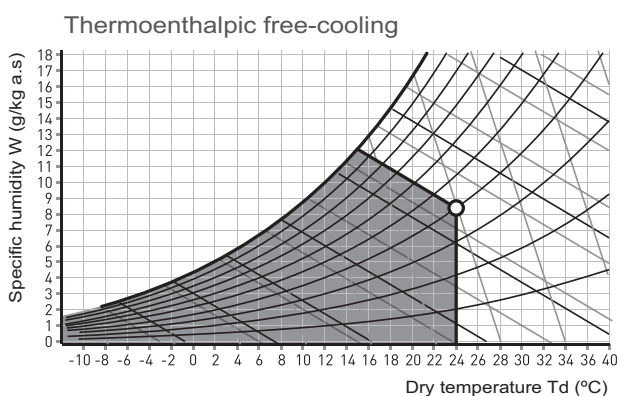
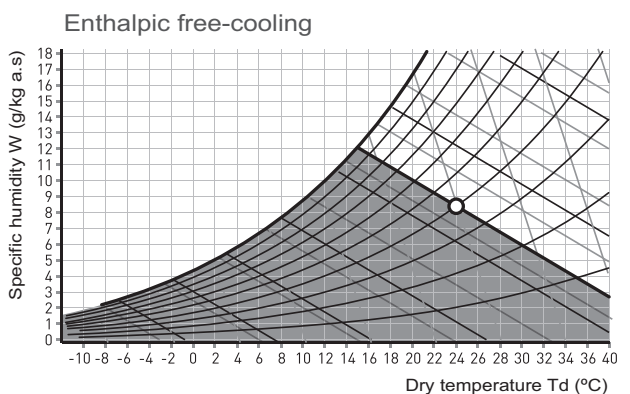
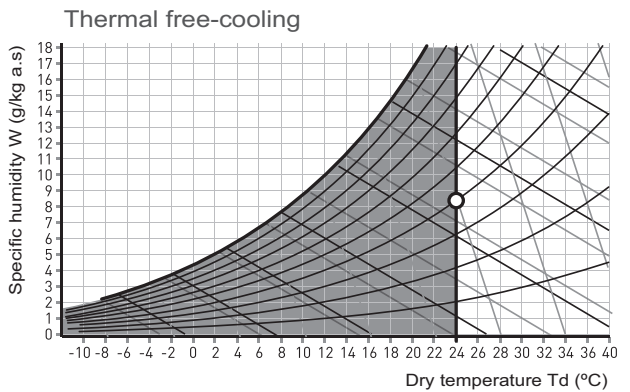

One function that helps improve energy management is **nocturnal free-cooling**. This feature allows the compressors to be disabled in summer with programming, the unit works providing free-cooling at night, when the outdoor conditions are favorable. This allows the cooling demand to decrease significantly early in the day.

■ **Outdoor air humidity sensor** (compulsory in units with optional enthalpic or thermoenthalpic free-cooling).

There are 2 options:

- Sensor supplied with the unit.
- Sensor installed on another unit of the local network (pLAN).

## FACTORY OPTIONS AND ACCESSORIES

### Terminal + unit communication

■ By default, the electronic control is supplied with a graphic terminal installed in the electrical cabinet of the unit, but these other configurations also are available:

- Graphic terminal installed in the electrical cabinet and User terminal remote up to 100 meters.
- Graphic terminal installed in the electrical cabinet and Graphic terminal remote up to 200 meters (two TCONN bypass cards must be used from 50 to 200 meters).
- User terminal installed in the electrical cabinet, instead of the graphic terminal.
- User terminal installed in the electrical cabinet and Graphic terminal remote up to 200 meters (two TCONN bypass cards must be used from 50 to 200 meters).
- Touch panel installed in the electrical cabinet, instead of the graphic terminal.
- Touch panel installed in the electrical cabinet and Graphic terminal remote up to 200 meters (two TCONN bypass cards must be used from 50 to 200 meters).
- Touch panel installed in the electrical cabinet and User terminal remote up to 100 meters.



Graphic terminal



Touch panel



User terminal

- Control without terminal (for units with shared terminal in a pLAN network).

■ By default, the electronic control is configured for a stand-alone unit, but it is also possible to place it in a pLAN network (Local Area Network) as Master, Slave or Back-up. The maximum number of units that can be configured on a Master/Slave pLAN network is 15, and in case of Back-up units is 2.

Important: to use any of the following functionalities it is necessary to configure in the "Selection software" one unit as Master and the others as Slaves (including the back-up unit). The specific functionality will be configured on site (according to the "50FC control manual").

The pLAN network allows to have the following functionalities depending on the parameterized configuration:

#### - Master/Slave:

It allows to share the VetricGD terminal, as well as some of the probes installed in the master unit: ambient temperature or ambient temperature + humidity, outdoor temperature, outdoor humidity and CO<sub>2</sub> air quality.

#### - Extended Master/Slave:

It includes "Master/Slave" functionalities and the master unit provides ambient temperature setpoints to the other units.

#### - Master/Slave with the same operating mode:

It includes the "Extended Master/Slave" functionalities and the master unit also provides the status (Cooling-Heating - Ventilation) to the other units.

#### - Back-up in case of alarm:

One unit is configured as a backup unit, in case of malfunction of the other pLAN network unit.

#### - Extended Back-up:

It includes the "Back-up in case of alarm" functionalities and also, the control manages the automatic switching between the two units weekly, to compensate the operation times of both units.

Note: In the case of installations with Back-up units, it is not possible to share the probes, nor the terminal, since both units must be fully autonomous in their operation. If both units are connected to the same supply duct network, it is imperative that the installation consists of overpressure dampers (installer responsibility).

■ This control allows the connection to a centralised technical management system by using a specific BMS card for some of the following communication protocols:

- RS485 serial cards for network communication with protocols: Carel, Modbus, LonWorks®, BACnet™ MSTP, Konnex.
- Ethernet pCO Web card for network communication with protocols: Modbus TCP/IP, BACnet™ Ethernet, TCP/IP, SNMP V1-2-3, FTP and HTTP.

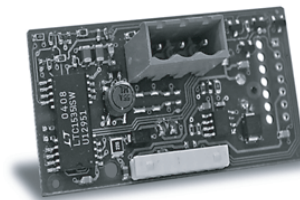

RS485 Carel/Modbus card

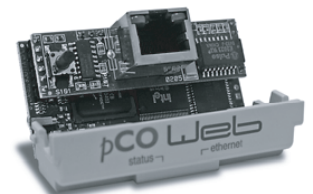

Ethernet pCO Web card

### Supervision solutions

Different solutions of supervision are available bases on the dimensions of the installation for unit fitted with Ethernet pCO Web and RS485 Carel / Modbus cards.

#### - pCO Web:

It is the solution for the management and supervision of a single unit if this incorporates the Ethernet pCO Web card.

#### - BOSS:

This is the solution for the management and supervision of air-conditioning installations with up to 300 units.

Its main advantages are:

- Integrated WIFI Hotspot for direct access without any extra infrastructure.
- Smartphone compatibility.
- Secure supervisor control from remote through a simple browser.

It offers advanced monitoring and maintenance functions and allows zones and groups to be created to simplify the management of the installation. It also allows energy meters to be integrated to monitor the installation electricity consumption.

## FACTORY OPTIONS AND ACCESSORIES

BOSS is available in two versions:

- CPU device.
- CPU device, monitor, keyboard and screen.

For this option, each unit needs one RS485 Carel / Modbus board.

### - BOSS mini (New)

This is the solution for the management and supervision of air-conditioning installations with up to 10 units with 50 variables per unit or 50 units with 10 variables maximum per unit, but with the same features as BOSS.

BOSS mini is available in two versions:

- CPU device, mouse and keyboard.
- CPU device, monitor, mouse and keyboard.

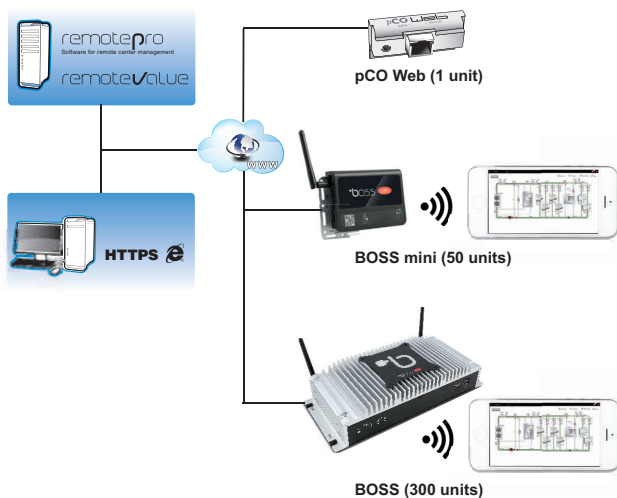

These systems are used to manage the installation remotely. All the information on the system can be accessed via a simple Internet connection. The online interface, the same one used by the local user, enables monitoring and complete configuration of the installation: from the office or anywhere else the user happens to be.

To control multiple sites remotely, there are special tools dedicated to centralized management, such as **RemotePRO** and **RemoteValue**.

### Miscellaneous item 1

- Management of an humidifier with on-off or proportional control.
- Electrical energy meter for monitoring of the power consumption of the installation.
- Energy meter and calculation of the cooling and heating capacities. In addition to the energy meter, the unit incorporates mixing and supply enthalpic sensors with RS485 communication that enable cooling and heating capacities to be calculated.
- Refrigerant leak detector (in ppm). This allows prompt identification of gas leaks, guaranteeing the safety of any people in the vicinity. This detector allows the number of periodic revisions to the unit to be reduced.

### Miscellaneous item 2

- Compressor soft starter.
- Varnish protection for the components on the electrical cabinet: control board, cards and terminals.

### Return fan

- Centrifugal return fan, coupled by pulleys and belts. Electric motor with tensioner, class F, IP55 and internal thermal protection. Turbine with an impeller of front-curved blades. Greased spherical bearings, with no maintenance required. Available in BB and BT assemblies.

There are 9 fan options depending on:

- Air flow: low, nominal and high.
- Available pressure: low, nominal and high.

- Return plug-fan with nominal available pressure, in Aluminium.

### Pre-assembly roofcurbs

- "Standard" assemblies can rest on pre-assembly roofcurbs with adjustable height, built in galvanised steel panelling with polyester paint and thermal insulation.

The levelling system uses angle pieces that allow adjustments in the X and Y axes.

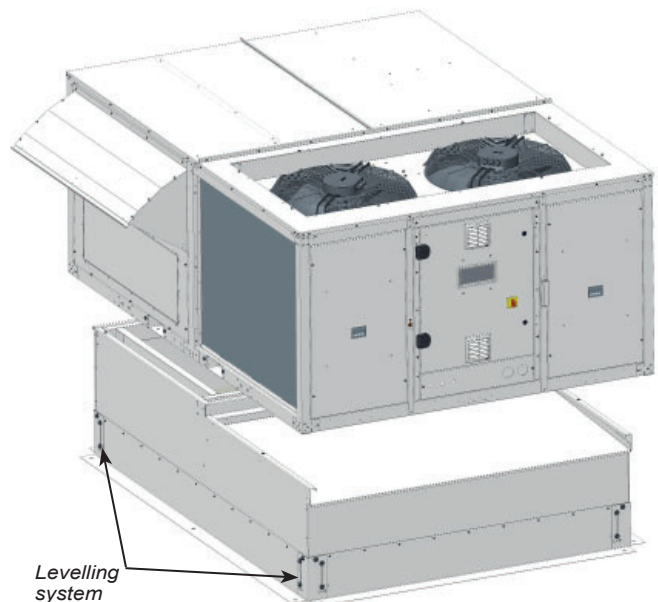

- Adaptation roofcurbs ready for direct replacement on site of units from different manufacturers (**upon request**). This option is available for both «Standard» and «In-line» assemblies.

## ADDITIONAL FACTORY OPTIONS UPON REQUEST

This chapter contains additional options available upon request, in addition to those already indicated in the table on the previous chapter:

Description	Installation in factory	Installation on site
Options of electronic control	Activation of the remote COOLING / HEATING operating mode	✓
	General alarm signalling by relay	✓
	Mechanical disconnection of stages	✓
	Ventilation mode with 100% fresh air by digital input	✓
	Control of supply and return dampers	✓
	Ventilation with differential air pressure sensor	✓
Constant supply pressure		✓
Adjustable pre-assembly roofcurbs with higher height		✓

### General alarm signalling

"50FC" control allows the management of a relay for remote alarm signalling.

The output for general alarm signal is not compatible with the following options: hot water coil, heat recovery coil, gas boiler, rotary heat exchanger and on/off signal for external humidifier. In this case, upon request, it would be possible to have a general alarm output in an input/output expansion module.

### Mechanical disconnection of stages

This option allows the mechanical disconnection of stages of compressor and/or electrical heaters using digital inputs. This is especially useful in the following cases:

- To reduce electricity consumption in certain time slots.
- When electricity consumption is limited.

### Ventilation mode with 100% fresh air by digital input

"50FC" control allows to manage a ventilation mode with 100% fresh air through the graphic terminal or by BMS supervision, but on certain occasions it may be interesting to activate this mode through a digital input. This option is especially useful when rapid air renewal is needed, for example in cinema rooms.

### Control of supply and return dampers

This function allows the management of external drive and return dampers located in the ducts, so that the closure of the ducts can be controlled after the unit is stopped. This option can also be useful in installations with Back-up units.

### Ventilation with differential air pressure sensor

In installations with this differential pressure sensor, the percentage of air renewal is adjusted according to the pressure in the room. This option allows dynamic control of the damper opening by measuring the pressure differential between inside and outside.

### Constant supply pressure

The 50FF/FC range provides the greatest choice in terms of multi-zone management. This new option of "Constant supply pressure" is added to the option "Air flow zoning up to 4 zones".

This function allows to control the air flow to maintain constant pressure in the supply duct, with the setpoint value set by parameter.

The following table provides the comparison of the two solutions to facilitate the correct selection according to the customer needs:

Characteristics	Zoning up to 4 zones	Constant supply pressure
Number of zones	Up to 4	Unlimited
Type of fan	Plug-fan	Plug-fan
Components included	4 zone terminals and a control box	Differential pressure sensor (range 0 - 1000 Pa)
Dampers and servos per zone	Not supplied	Not supplied
Control signal for dampers / servos	Supplied	Not supplied (external control required)
Control of the damper for each zone	Yes, control carried out by the electronic control	No (at customer level)
Terminal in each zone	Yes	No or just one for the main zone (see "Configurations")
Minimum air flow	35%	35% or 10% in ventilation mode (operating only the fans). There is an associated alarm in case of lower airflow. It is necessary to set the minimum damper opening per zone or provide remote stop control in case all dampers are closed
Capacity control	Based on the ambient temperature conditions of each zone terminal (by default) or the return temperature (optional)	<ul style="list-style-type: none"> <li>• Based on the return conditions (by default)</li> <li>• Based on the environment conditions (configurable), in case of a main zone (see "Configurations")</li> </ul>

Configurations	
Capacity control based on the return conditions (by default)	Capacity control based on the environment conditions (configurable)
Several zones	Several zones (one main zone)
Same comfort priority by zone	One main zone. Comfort of all zones depends on the demand of the main zone

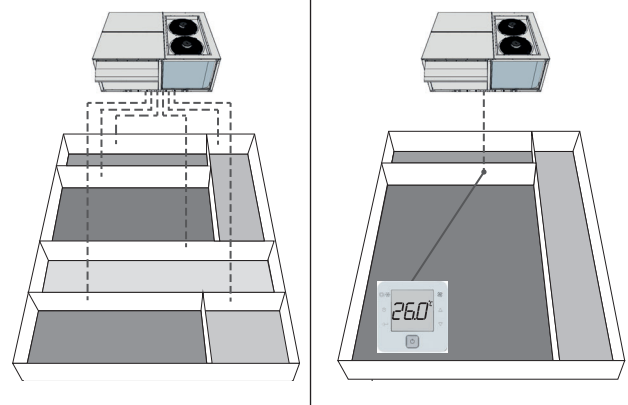

Note: For variable management of fresh air it is necessary to select the optional return air quality probe (CO<sub>2</sub>) (instead of the ambient probe).

There is only one case in which the ambient air quality probe can be used: with constant supply pressure and capacity based on the environmental conditions of the main zone.



## ELECTRICAL CONNECTIONS

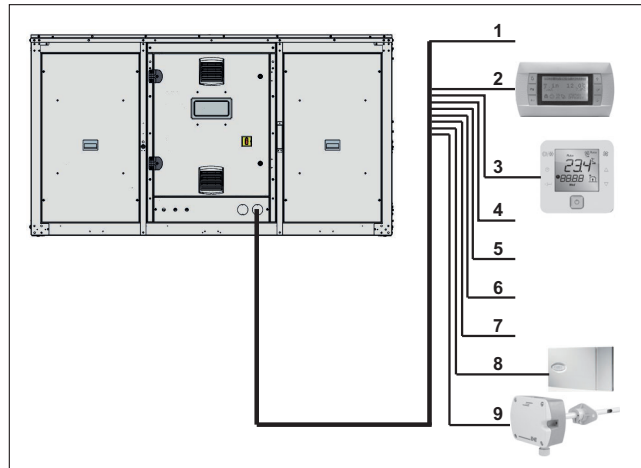

No.	50FF/FC	020 to 099
1	Main power supply 400 III ( $\pm 10\%$ )	3 Wires + Ground + Neutral
2	Remote connection of graphic terminal (by default installed on the electrical cabinet) (1)	Telephone cable 6 wires standard (RJ12 connector)
3	Connection of user terminal (optional) (2)	2 wires for power supply 230V + 1 shielded cable for communication type AGW20 / 22 (1 braided pair + drainwire + shielding)
4	Remote off/on (optional)	2 wires
5	General fault signal (optional) (3)	2 wires
6	Remote Cooling/Heating (optional upon request)	2 wires
7	Circulation pump signal for HWC (antifreeze safety) (optional)	1 wire
8	Ambient sensor NTC RS485	2 wires
		5 wires (4)
9	CO <sub>2</sub> sensor (optional)	3 wires

- (1) In this case, it's possible to install the user terminal on the electrical cabinet.
- (2) It's necessary that the terminal uses the same power supply that the control board.
- (3) The output for general alarm signal is not compatible with the following options: hot water coil, heat recovery coil, gas boiler, rotary heat exchanger and on/off signal for external humidifier. With these options, possibility of general alarm upon request.
- (4) Up to four RS485 ambient sensors can be connected in series on the field-bus of the control board.

## OPTIONS FOR THE OUTDOOR CIRCUIT

### Axial 2-speed outdoor fan

50FF/FC		020	028	037	040	045	047	052	058	062	070	074	086	093	099	
Cooling: efficiency with R-410A	50FF	SEER	4,04	3,70	3,72	3,65	3,64	3,65	3,61	3,66	3,71	3,71	3,73	3,72	3,70	--
		$\eta_s$	158%	145%	146%	143%	142%	143%	141%	144%	145%	145%	146%	146%	145%	--
	50FC	SEER	4,11	3,75	3,74	3,70	3,63	3,62	3,55	3,65	3,67	3,72	3,69	3,57	3,56	3,75
		$\eta_s$	162%	147%	147%	145%	142%	142%	139%	143%	144%	146%	145%	140%	139%	147%
Heating: efficiency with R-410A	50FC	SCOP	3,20	3,21	3,21	3,20	3,22	3,21	3,21	3,20	3,21	3,22	3,26	3,27	3,22	3,20
		$\eta_s$	125%	126%	125%	125%	126%	125%	125%	125%	125%	126%	128%	128%	126%	125%
Nominal air flow (m <sup>3</sup> /h)		9.000	14.500	17.000	17.000	17.000	17.750	31.000	31.000	31.000	33.000	33.000	34.500	35.000	39.500	
Available static pressure (mm.w.c.)		4														
Number / Diameter (mm)		1 / 630	1 / 800				2 / 800									
Maximum speed (r.p.m.)		690 / 840	670 / 880				670 / 880									
Output (kW)		0,4 / 0,6	1,2 / 1,9				2 x (1,2 / 1,9)									
Max. absorbed current (A)		1,2	3,9				2 x 3,9									

## OPTIONS FOR THE INDOOR CIRCUIT

### Supply plug-fan with different available pressure options

50FF/FC		020	028	037	040	045	047	052	058	062	070	074	086	093	099
Nominal air flow	(m³/h)	5.100	6.500	8.500	8.750	9.000	9.000	12.000	12.500	12.500	15.500	15.500	16.000	16.000	18.000
Nominal available static pressure	(mm.w.c.)	12	12	12	15	15	15	20	20	20	20	20	20	25	25
Nominal pressure, Aluminium (M)	Number / Diameter (mm)	1 / 500		2 / 560				2 / 500							
	Speed (r.p.m.)	1.855		1.630				1.855							
	Output (kW)	3,1		2 x 4,1				2 x 3,1							
	Max. absorbed current (A)	4,8		2 x 6,2				2 x 4,8							
Low pressure (F)	Number / Diameter (mm)	1 / 500		--				1 / 500 (*)		--		2 / 500			
	Speed (r.p.m.)	1.350		--				2.100 (*)		--		1.800			
	Output (kW)	1,3		--				4,8 (*)		--		2 x 3,1			
	Max. absorbed current (A)	2,1		--				7,3 (*)		--		2 x 4,7			
High pressure (S)	Number / Diameter (mm)	1 / 500		2 / 500				2 / 500							
	Speed (r.p.m.)	1.855		1.800				2.100							
	Output (kW)	3,1		2 x 3,1				2 x 4,8							
	Max. absorbed current (A)	4,8		2 x 4,7				2 x 7,3							

(\*) Not available for In-line models

Note: the value of power input according to the selected flow can be found at our "Selection Software".

### Axial fan in return section (BX assembly)

50FF/FC		020	028	037	040	045	047	052	058	062	070	074	086	093	099
Air flow	(m³/h)	5.100	6.500	8.500	8.750	9.000	9.000	12.000	12.500	12.500	15.500	15.500	16.000	16.000	18.000
Available static pressure	(mm.w.c.)	5													
Number / Diameter	(mm)	1 / 500		2 / 450				2 / 500				3 / 500			
Output	(kW)	0,7		2 x 0,5				2 x 0,7				3 x 0,7			
Speed	(r.p.m.)	1.390		1.360				1.390				1.390			
Maximum absorbed current	(A)	1,4		2 x 1,0				2 x 1,4				3 x 1,4			

### Return plug-fan (BP / BA / BT / BB / RP assemblies)

50FF/FC		020	028	037	040	045	047	052	058	062	070	074	086	093	099	
Nominal air flow	(m³/h)	5.100	6.500	8.500	8.750	9.000	9.000	12.000	12.500	12.500	15.500	15.500	16.000	16.000	18.000	
Nominal available static pressure	(mm.w.c.)	12	12	12	15	15	15	20	20	20	20	20	20	25	25	
Nominal pressure (standard)	Number / Diameter (mm)	1 / 500					2 / 500									
	Speed (r.p.m.)	1.800					1.800									
	Output (kW)	3,1					2 x 3,1									
	Max. absorbed current (A)	4,7					2 x 4,7									
Nominal pressure, Aluminium (optional)	Number / Diameter (mm)	1 / 500					2 / 500 (*)				2 / 500					
	Speed (r.p.m.)	1.855					1.855 (*)				1.855					
	Output (kW)	3,1					2 x 3,1 (*)				2 x 3,1					
	Max. absorbed current (A)	4,8					2 x 4,8 (*)				2 x 4,8					

(\*) Only available with BT / BB assemblies.

Note: the value of power input according to the selected flow can be found at our "Selection Software".

# OPTIONS FOR THE INDOOR CIRCUIT

## Return plug-fan (BW / RW assemblies)

50FF/FC		020	028	037	040	045	047	052	058	062	070	074	086	093	099
Nominal air flow	(m³/h)	5.100	6.500	8.500	8.750	9.000	9.000	12.000	12.500	12.500	15.500	15.500	16.000	16.000	18.000
Nominal available static pressure	(mm.w.c.)	12	12	12	15	15	15	20	20	20	20	20	20	25	25
Nominal pressure (standard)	Number / Diameter (mm)	1 / 500		1 / 500				2 / 500			2 / 500				
	Speed (r.p.m.)	1.800		1.855				1.800			1.855				
	Output (kW)	3,1		3,1				2 x 3,1			2 x 3,1				
	Max. absorbed current (A)	4,7		4,8				2 x 4,7			2 x 4,8				
Nominal pressure, Aluminium (optional)	Number / Diameter (mm)	1 / 500				--			2 / 500						
	Speed (r.p.m.)	1.855				--			1.855						
	Output (kW)	3,1				--			2 x 3,1						
	Max. absorbed current (A)	4,8				--			2 x 4,8						

Note: the value of power input according to the selected flow can be found at our "Selection Software".

## Heat recovery wheel module (BW / RW assemblies)

This heat recovery wheel is used to transfer the sensible and latent heat from the air-conditioned room's return air to the fresh air used for ventilation, before it's discharged outdoors. The return air circulates in half of the heat recovery unit and the ventilation air circulates in the other half, in the opposite direction. As the rotor rotates, very fine channels of air which form the matrix come into contact with the fresh air and the return air in turn, thereby transferring heat and humidity from one to the other.

The efficiency of the recovery depends on the following factors:

■ **Wheel diameters:**

- 800 mm: models 020 to 047
- 1300 mm: models 052 to 062
- 1600 mm: models 070 to 099

■ **Matrix materials:**

- Aluminium: sensible heat recovery.
- Epoxy coated aluminium: sensible heat recovery in aggressive environments.
- Hybrid wheel: enthalpic recovery.
- Silicagel coated aluminium: enthalpic recovery with high efficiency in the recovery of latent heat.

■ **Channel cross section:**

The wheel is formed of two panels of aluminium, one smooth and one fluted. The fluted panel can be provided in two different configurations:

- 2.0 mm cross section: the commonly-used cross section due to its high efficiency and moderate pressure drops.
- 2.5 mm cross section: low pressure drop. Designed for high frontal speeds with low pressure drops.

The heat recovery wheel is fitted into a module placed on one side of the unit.

This module features gravimetric filters G4 with low pressure drop both on the fresh air intake and on the exhaust air outlet.

This assembly can be supplied, in option, with a speed drive for the wheel which avoids the risk of ice forming on the wheel during the defrost operation.

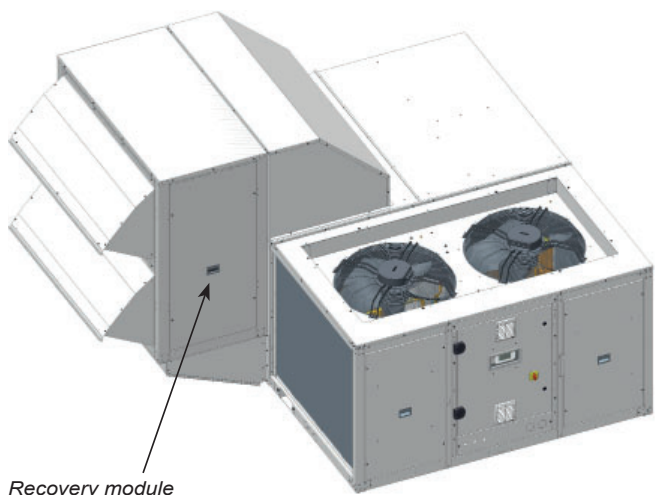

Note: It's recommended to use a CO<sub>2</sub> air quality sensor (optional) in units with rotary heat exchanger.

**Important:** the calculations for the selection of a heat recovery wheel according to the parameters described above should be done using our "Selection Software".

# OPTIONS FOR THE INDOOR CIRCUIT

## Centrifugal return fan (BT / BB assemblies)

50FF/FC		020	028	037	040	045	047	052	058 062	070 074	086 093	099
Option A: Low flow + nominal pressure	Available pressure (mm.w.c.)	20										
	Air flow (m³/h)	4.080	5.200	6.800	7.000	7.200	7.200	9.600	10.000	12.400	12.800	14.400
	Motor output (kW)	0,75	1,10	1,50	2,20	2,20	2,20	2,20	2,20	2 x 1,50	2 x 1,50	2 x 2,2
	Power input (kW)	0,73	1,20	1,46	1,65	1,73	1,73	1,88	2,06	2 x 1,22	2 x 1,30	2 x 1,73
	Max. abs. current (A)	2,10	3,20	4,10	6,90	6,90	6,90	6,90	6,90	2 x 4,10	2 x 4,10	2 x 6,9
	Speed (r.p.m.)	888	976	806	830	839	839	683	696	779	788	839
	OPK code	0671	0673	0677	0684	0684	0684	0682	0682	2 x 0677	2 x 0677	2 x 0684
Option B: Low flow + high pressure	Available pressure (mm.w.c.)	50										
	Air flow (m³/h)	4.080	5.200	6.800	7.000	7.200	7.200	9.600	10.000	12.400	12.800	14.400
	Motor output (kW)	1,50	2,20	3,00	3,00	3,00	3,00	3,00	4,00	2 x 2,20	2 x 2,20	2 x 3
	Power input (kW)	1,26	1,78	2,26	2,50	2,59	2,59	2,96	3,12	2 x 2,02	2 x 2,11	2 x 2,59
	Max. abs. current (A)	4,10	6,90	7,20	7,20	7,20	7,20	7,20	9,00	2 x 6,90	2 x 6,90	2 x 7,2
	Speed (r.p.m.)	1.326	1.341	1.133	1.139	1.142	1.142	954	958	1.130	1.131	1.142
	OPK code	0672	0674	0680	0680	0680	0680	0681	0683	2 x 0676	2 x 0676	2 x 0680
Option C: Nominal flow + nominal pressure	Available pressure (mm.w.c.)	20										
	Air flow (m³/h)	5.100	6.500	8.500	8.750	9.000	9.000	12.000	12.500	15.500	16.000	18.000
	Motor output (kW)	1,10	1,50	1,50	2,20	2,20	2,20	2,20	2,20	2 x 1,50	2 x 1,50	2 x 2,2
	Power input (kW)	1,15	1,26	1,55	1,73	1,81	1,81	2,00	2,18	2 x 1,30	2 x 1,38	2 x 1,81
	Max. abs. current (A)	3,20	4,10	4,10	6,90	6,90	6,90	6,90	6,90	2 x 4,10	2 x 4,10	2 x 6,9
	Speed (r.p.m.)	967	783	656	672	679	679	545	553	637	644	679
	OPK code	0673	0677	0678	0682	0682	0682	0685	0685	2 x 0678	2 x 0678	2 x 0682
Option D: Nominal flow + high pressure	Available pressure (mm.w.c.)	50										
	Air flow (m³/h)	5.100	6.500	8.500	8.750	9.000	9.000	12.000	12.500	15.500	16.000	18.000
	Motor output (kW)	2,20	2,20	3,00	3,00	3,00	3,00	4,00	4,00	2 x 3,00	2 x 3,00	2 x 3
	Power input (kW)	1,72	2,07	2,56	2,79	2,88	2,88	3,46	3,67	2 x 2,30	2 x 2,39	2 x 2,88
	Max. abs. current (A)	6,90	6,90	7,20	7,20	7,20	7,20	9,00	9,00	2 x 7,20	2 x 7,20	2 x 7,2
	Speed (r.p.m.)	1.338	1.130	949	951	953	953	797	799	949	949	953
	OPK code	0674	0676	0681	0681	0681	0681	0686	0686	2 x 0681	2 x 0681	2 x 0681
Option E: High flow + nominal pressure	Available pressure (mm.w.c.)	20										
	Air flow (m³/h)	6.120	7.800	10.200	10.500	10.800	10.800	14.400	15.000	18.600	19.200	19.200
	Motor output (kW)	1,10	1,50	2,20	2,20	2,20	2,20	3,00	4,00	2 x 2,20	2 x 2,20	2 x 2,20
	Power input (kW)	1,13	1,24	2,28	1,72	1,79	1,79	2,90	3,14	2 x 1,88	2 x 2,01	2 x 2,01
	Max. abs. current (A)	3,20	4,10	6,90	6,90	6,90	6,90	7,20	9,00	2 x 6,90	2 x 6,90	2 x 6,90
	Speed (r.p.m.)	766	633	711	533	536	536	585	597	683	693	693
	OPK code	0675	0678	0682	0685	0685	0685	0687	0689	2 x 0682	2 x 0682	2 x 0682
Option F: High flow + high pressure	Available pressure (mm.w.c.)	50										
	Air flow (m³/h)	6.120	7.800	10.200	10.500	10.800	10.800	14.400	15.000	18.600	19.200	19.200
	Motor output (kW)	2,20	2,20	4,00	4,00	4,00	4,00	5,50	5,50	2 x 3,00	2 x 4,00	2 x 4,00
	Power input (kW)	1,90	2,26	3,35	3,12	3,21	3,21	4,51	4,83	2 x 2,96	2 x 3,07	2 x 3,07
	Max. abs. current (A)	6,90	6,90	9,00	9,00	9,00	9,00	11,60	11,60	2 x 7,20	2 x 9,00	2 x 9,00
	Speed (r.p.m.)	1.131	950	964	796	796	796	809	814	954	957	957
	OPK code	0676	0679	0683	0686	0683	0683	0688	0688	2 x 0681	2 x 0683	2 x 0683
Option G: Low flow + low pressure	Available pressure (mm.w.c.)	8										
	Air flow (m³/h)	4.080	5.200	6.800	7.000	7.200	7.200	9.600	10.000	12.400	12.800	14.400
	Motor output (kW)	0,55	0,55	1,10	1,50	1,50	1,50	1,10	1,10	2 x 0,55	2 x 1,10	2 x 1,5
	Power input (kW)	0,42	0,41	0,89	1,05	1,11	1,11	0,56	0,56	2 x 0,40	2 x 0,78	2 x 1,11
	Max. abs. current (A)	1,60	1,60	3,20	4,10	4,10	4,10	3,20	3,20	2 x 1,60	2 x 3,20	2 x 4,1
	Speed (r.p.m.)	710	549	670	701	712	712	358	358	431	646	712
	OPK code	0690	0691	0694	0677	0677	0677	0699	0699	2 x 0693	2 x 0694	2 x 0677
Option H: Nominal flow + low pressure	Available pressure (mm.w.c.)	8										
	Air flow (m³/h)	5.100	6.500	8.500	8.750	9.000	9.000	12.000	12.500	15.500	16.000	18.000
	Motor output (kW)	0,55	0,55	1,10	0,75	1,10	1,10	1,50	1,50	2 x 1,10	2 x 1,10	2 x 1,1
	Power input (kW)	0,41	0,40	0,80	0,66	0,56	0,56	1,16	0,95	2 x 0,74	2 x 0,80	2 x 0,56
	Max. abs. current (A)	1,60	1,60	3,20	2,10	3,20	3,20	4,10	4,10	2 x 3,20	2 x 3,20	2 x 3,2
	Speed (r.p.m.)	549	431	504	380	358	358	430	410	500	510	358
	OPK code	0691	0693	0695	0697	0699	0699	0698	0698	2 x 0695	2 x 0695	2 x 0699
Option I: High flow + low pressure	Available pressure (mm.w.c.)	8										
	Air flow (m³/h)	6.120	7.800	10.200	10.500	10.800	10.800	14.400	15.000	18.600	19.200	19.200
	Motor output (kW)	0,75	1,50	1,10	1,50	1,50	1,50	3,00	3,00	2 x 1,10	2 x 1,10	2 x 1,10
	Power input (kW)	0,64	1,33	0,86	0,95	1,01	1,01	1,85	2,06	2 x 0,56	2 x 0,56	2 x 0,56
	Max. abs. current (A)	2,10	4,10	3,20	4,10	4,10	4,10	7,20	7,20	2 x 3,20	2 x 3,20	2 x 3,20
	Speed (r.p.m.)	613	752	403	410	416	416	486	501	358	358	358
	OPK code	0692	0677	0696	0698	0698	0698	0700	0700	2 x 0699	2 x 0699	2 x 0699

# OPTIONS FOR THE INDOOR CIRCUIT

## Cooling recovery circuit (BA / BB assemblies)

Thermodynamic circuit dedicated to the recovery of the extracted air energy, with independent and proportional control, adapted to the air renewal requirements in order to raise the COP, EER and seasonal efficiency of the unit set.

- The circuit is composed of:
  - EC plug-fan in return section.
  - Air circuit comprised of coils with copper pipes and aluminium fins.
  - Electronic expansion valve.
  - Hermetic scroll-type compressor with sound insulation, assembled over antivibration mounts.
  - Crankcase heater.
  - Four-way cycle reversing valve.
  - Anti-acid dehydrator filter.
  - High and low pressure transducers.
  - Condensates drain pan.

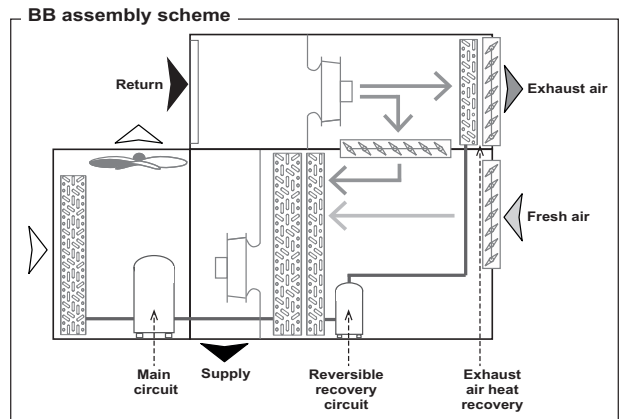
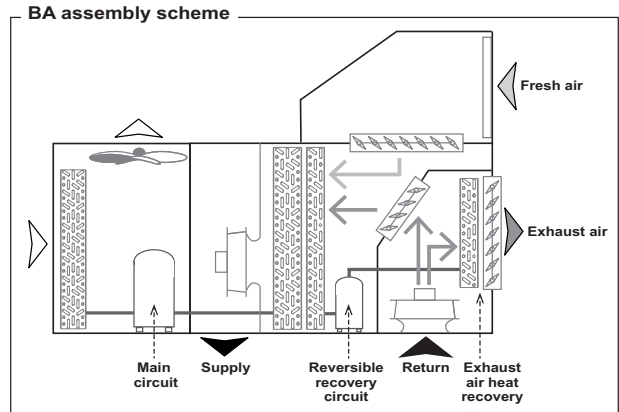

50FF/FC	020 to 028	037 to 047	052 to 062	070 to 099
Compressor type	Scroll			
No. of compressors / circuits	1 / 1			
Max. absorbed current (A)	5,1	6,3	9,7	11,6
Oil type	Copeland 3MAF 32cST, Danfoss POE 160SZ, ICI Emkarate RL 32CF, Mobil EAL Artic 22CC			
Volume of oil (l)	0,7	1,2	1,7	1,8
Charge of R-410A (kg)	1,7	2,5	3,0	3,4
Environment impact (tCO <sub>2</sub> eq)	3,5	5,2	6,3	7,1

## Total cooling capacity with recovery circuit

50FF/FC		020	028	037	040	045	047	052	058	062	070	074	086	093	099	
Nominal air flow	(m <sup>3</sup> /h)	5.100	6.500	8.500	8.750	9.000	9.000	12.000	12.500	12.500	15.500	15.500	16.000	16.000	18.000	
Outdoor temperature 35°C / 40% RH Indoor temperature 27°C / 50% RH	20% fresh air	Pft (kW)	29,6	36,2	45,7	49,4	54,2	56,5	70,4	75,4	77,8	90,6	94,5	103,2	112,4	122,0
		Pfs (kW)	23,7	29,6	38,1	40,2	42,4	43,3	55,9	59,0	59,9	72,1	73,6	78,1	81,6	89,0
		Pa (kW)	8,5	9,6	11,5	12,8	14,0	14,7	17,8	19,5	20,5	21,7	23,3	25,8	29,0	34,4
	40% fresh air	Pft (kW)	31,3	37,9	48,2	52,0	56,8	59,3	73,8	78,8	81,4	95,1	99,2	107,9	117,4	127,0
		Pfs (kW)	25,1	31,2	39,7	41,8	44,2	45,2	58,8	62,0	62,9	76,0	77,4	81,9	85,5	92,5
		Pa (kW)	8,1	9,3	10,9	12,3	13,5	14,2	17,1	18,9	19,9	20,9	22,5	25,1	28,3	33,8
	80% fresh air	Pft (kW)	33,7	40,3	51,9	55,7	60,7	63,2	78,8	84,1	86,8	102,3	106,3	115,0	125,1	135,0
		Pfs (kW)	27,5	33,7	42,4	44,4	47,0	47,8	62,4	65,8	66,9	82,3	84,0	87,9	92,6	98,6
		Pa (kW)	7,9	9,1	10,6	12,1	13,4	14,0	16,8	18,5	19,6	20,6	22,2	24,9	28,2	33,9

Pft: Total gross cooling capacity (sum of the power of the main circuit and the recovery circuit)

## Total heating capacity with recovery circuit

50FF/FC		020	028	037	040	045	047	052	058	062	070	074	086	093	099	
Nominal air flow	(m <sup>3</sup> /h)	5.100	6.500	8.500	8.750	9.000	9.000	12.000	12.500	12.500	15.500	15.500	16.000	16.000	18.000	
Outdoor temperature 6°C BH Indoor temperature 20°C	20% fresh air	Pct (kW)	29,7	35,8	44,3	47,9	53,0	55,7	68,3	73,5	76,2	87,8	91,9	100,9	110,2	120,0
		Pa (kW)	6,7	7,9	9,3	10,3	11,6	12,4	14,7	16,2	17,1	18,8	20,1	22,6	25,8	29,9
	40% fresh air	Pct (kW)	31,1	37,1	46,2	49,8	55,0	64,4	71,0	76,2	79,0	91,1	95,2	104,2	113,7	124,0
		Pa (kW)	6,4	7,5	8,9	9,9	11,1	11,9	14,1	15,5	16,4	18,0	19,3	21,7	24,7	28,4
	80% fresh air	Pct (kW)	32,8	39,0	47,8	52,3	57,7	60,4	74,8	80,1	83,0	95,6	99,8	108,9	118,7	129,0
		Pa (kW)	5,9	6,8	8,1	9,0	10,1	10,9	12,9	14,1	14,9	16,5	17,6	19,8	22,5	25,4

Pct: Total gross heating capacity (sum of the power of the main circuit and the recovery circuit)

## OPTIONS FOR THE INDOOR CIRCUIT

### Auxiliary hot water coil

Auxiliary hot water coil, with three-way valve and proportional control, for assembly and connection inside the unit. This option always incorporates a freeze protection thermostat.

50FF/FC		020	028	037	040	045	047	052	058	062	070	074	086	093	099
Air pressure drop (mm.w.c.)		2,4	3,5	3,5	3,6	4,3	4,3	3,4	3,6	3,6	3,5	3,7	3,7	3,7	4,5
Water 80/60°C and inlet air 20°C	Heating capacity (kW)	27,6	32,0	47,6	48,4	49,2	49,2	95,8	98,3	98,3	129,0	129,0	131,5	131,5	141,5
	Water flow (m³/h)	1,4	1,6	2,1	2,1	2,1	2,1	2,7	2,8	2,8	3,6	3,6	3,7	3,7	3,9
	Water pressure drop (m.w.c.)	0,2	0,3	0,5	0,5	0,5	0,5	0,5	0,5	0,5	0,9	0,9	1,0	0,9	1,3
Water 90/70°C and inlet air 20°C	Heating capacity (kW)	34,2	39,8	58,7	59,8	90,8	90,8	118,5	121,5	121,5	158,7	158,7	161,9	161,9	174,7
	Water flow (m³/h)	1,7	2,0	2,6	2,6	2,6	2,6	3,4	3,4	3,4	4,5	4,5	4,6	4,6	4,9
	Water pressure drop (m.w.c.)	0,3	0,4	0,7	0,7	0,8	0,8	0,7	0,7	0,7	1,3	1,4	1,4	1,4	1,7

Note: Maximum water inlet temperature 95°C, maximum pressure 4 bar.

Note: the hot water coil is not compatible with the droplet eliminator after the indoor air coil, the heat recovery coil or the active dehumidification.

### Position of the hydraulic connections of the hot water coil

The inlet/outlet connections of the hot water coil are located inside the unit and the connection is made via the side panel.

In models 052 to 099 it can also be made via the base of the unit using flexible piping (only available for units without pre-assembly roofcurb).

The position of the sheet metal precuts on the side panel are shown in the following diagrams.

**“Standard” assemblies**

50FF/FC	Dimensions (mm)			
	A	B	C	Ø
020 to 047	142	160	158	1 ¼"
052 to 099	159	245	158	2"

**“In-line” assemblies**

50FF/FC	Dimensions (mm)			
	A	B	C	Ø
052 to 062	934	280	158	2"
070 to 093	1314	280	158	2"

### “Very low outdoor temperature” option (HAF)

Note: on units with the “Very low outdoor temperature” option, air supply only may be lateral (factory-configured).

■ This anti-freeze safety incorporates:

- Circulation pump.
- Water temperature sensors located in the inlet and the outlet of the coil.

Important: this option is mandatory for an outdoor temperature lower than -20°C WB. Consult for percentages of glycol water above 20%.

■ Characteristics of the water circuit:

50FF/FC		020 to 047	052 to 099
Circulation pump	Motor output (W)	90	140
	Max. absorbed current (A)	0,75	1,15

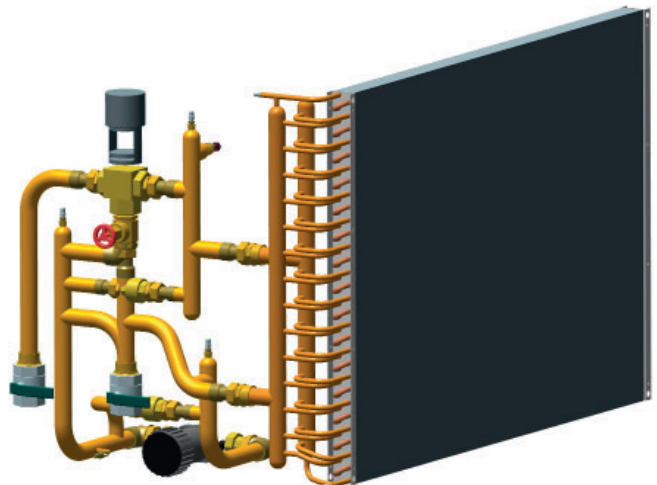

## OPTIONS FOR THE INDOOR CIRCUIT

### Gas-fired condensing boiler with hot water coil

Gas-fired condensing boiler with modulating actuator, in accordance with the Gas Directive 2009/142/EC, mounted on the side of the unit.

EC certification: 0085CP0214.

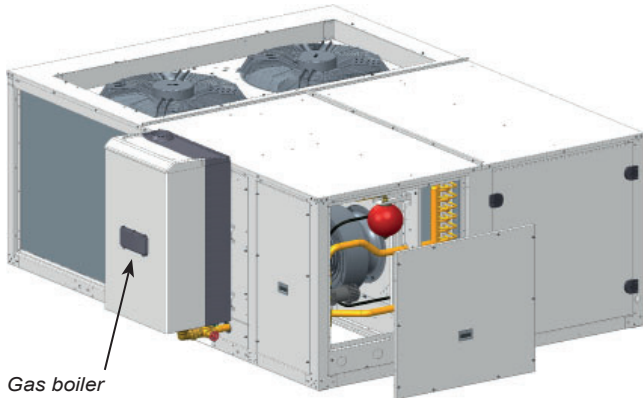

Gas boiler

■ Up to 3 values of total power available for each model:

50FF/FC	020 to 047	052 to 099
BBF (Low)	unavailable	unavailable
BBM (Nominal)	unavailable	Condexa PRO 70
BBS (High)	Condexa PRO 70	Condexa PRO 100

Note: the gas boiler is not compatible with the droplet eliminator after the indoor coil, the heat recovery coil or the active dehumidification.

■ The key features of the boiler are:

- Natural or propane gas boiler.
- Burner with premixing and modulation technology that allows outputs close to 109% (Hi performance).
- Heat exchanger made of stainless steel with a low carbon content.
- Proportional air / gas valve. Low NOx emissions (class 5, according to standard EN 297).
- Condensate drain with siphon.
- Forced draught.
- Electronic ignition.
- Safety devices: safety thermostat, low water pressure safety switch, flowmeter, Delta-T control, smoke temperature sensor.
- NTC sensor for boiler water temperature regulation.
- Working temperature of water from -7°C to 100°C. Consult for percentages of glycol water above 20%.
- Electronic controller with microprocessor and Multifunction LCD display for boiler's control, configuration and diagnostics. Possibility of ModBus communication.
- The electronic control of the unit will only manage the boiler connection as heating support depending on the ambient conditions.

■ The boiler is connected to the hydraulic circuit of the auxiliary hot water coil.

The water circuit, installed inside the unit, is composed of:

- Water coil.
- Circulation pump.
- Expansion vessel.
- Gate valves.
- Safety valve with a tare value of 4 bar.
- Automatic air bleeder valve.

■ Characteristics of the water circuit:

	50FF/FC	020 to 047	052 to 099
Expansion vessel	Volume (l)	5	5
	Filling pressure (kg/cm <sup>2</sup> )	1,5	1,5
Circulation pump	Motor output (W)	90	140
	Max. absorbed current (A)	0,75	1,15

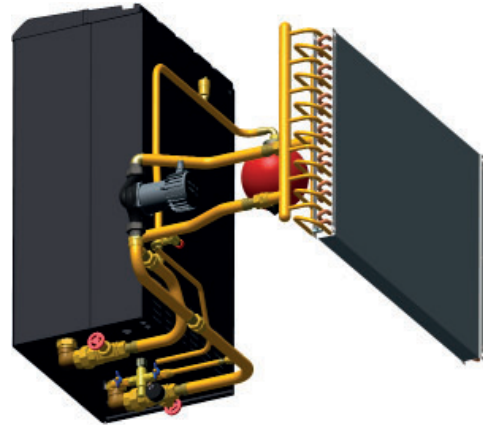

■ Type of gas used depending on the destination country:

Country	Category	Gas	Pressure (mbar)	Gas	Pressure (mbar)
Italy, Ireland, Great Britain, Portugal, Slovenia, Slovakia, Greece	I12H3+	G20	20	G30/G31	28-30/37
Spain	I12H3+	G20	18	G30/G31	28-30/37
Romania, Bulgaria, Turkey, Denmark, Estonia, Sweden, Norway, Latvia, Lithuania, Finland, Russia	I12H3B/P	G20	20	G30	30
Hungary	I12H3B/P	G20	25	G30	30
Poland	I12H3B/P	G20	25	G30	37
Croatia	I12H3B/P	G20	20	G30/G31	30
Holland	I12H3B/P	G25	25	G30	30
Czech Rep., Austria, Switzerland	I12H3B/P	G20	20	G30	50
Luxembourg	I12H3B/P	G20	20	G30	50
	I12E3P	G20	20	G31	37
Belgium	I2E(S)	G20/G25	20/25	--	--
	I3+	--	--	G30/G31	28-30/37
France	I12E+3+,	G20/G25	20/25	G30/G31	28-30/37
Malta, Cyprus, Iceland	I3B/P	--	--	G30	30
Germany	I12ELL3B/P	G20/G25	25	G30	50

## OPTIONS FOR THE INDOOR CIRCUIT

■ Technical characteristics of the boiler:

Model		Condexa PRO 70	Condexa PRO 100	
Type of equipment		B23 - B53 - B53P		
NOx Class (according to standard EN 297)		5		
Boiler performance	Total thermal power (Hs)	kW	76/15	108/21,6
	Total thermal power (Hi)	kW	68/14	97/19,4
	Nominal power supplied to the water 100% (80°C - 60°C)	kW	66,7	95,2
	Nominal power supplied to the water 100% (50°C - 30°C)	kW	73,5	105
	Nominal power supplied to the water 100% (60°C - 40°C)	kW	71	101
	Condensate hourly production 100% (50°C - 30°C) with G20	kg/h	8,5	12,3
	Performance with nominal power (80°C - 60°C)	%	98,1	98,1
	Performance with nominal power (50°C - 30°C)	%	108,1	108,2
	Performance with nominal power Tm = 50°C (60°C - 40°C)	%	104,4	104,1
	Performance with reduced load 30% (80°C - 60°C)	%	98,5	98,3
	Performance with reduced load 30% (50°C - 30°C)	%	109	109
	Performance with reduced load 30% Tm = 50°C (60°C - 40°C)	%	105,3	105
Losses in enclosure (Tm = 70°C)	%	0,1		
Energy efficiency marking (Directive 92/42 EC)		★★★★		
Energy efficiency	Seasonal energy efficiency class in heating	A	A	
	Seasonal energy efficiency in heating	%	92,7	92,7
Gas supply	Gas category	II2H3+		
	Natural Gas consumption (G20) (nominal / minimum)	m³/h	7,2/1,4	10,3/2,1
Electrical data	Power supply	230 Vac - 50 Hz		
	Power input at 100%	W	77	203
	Power input at 30%	W	30	31
	Power input in stand-by	W	13	6
	Ingress protection rating	IP X5D		
	Operating temperatures	from -15°C to +70°C		
Connections	Ø Gas supply	G1"	G1"	
	Ø Flue outlet	mm	DN80	DN110
	Ø Condensate drain	mm	25	25
Heating circuit	Control of heating temperature (min. / max.)	°C		20 / 80
	Working pressure (max. / min.)	bar		6 / 0,7

### Location of the gas burner

50FF/FC 020-028-037-040-045-047

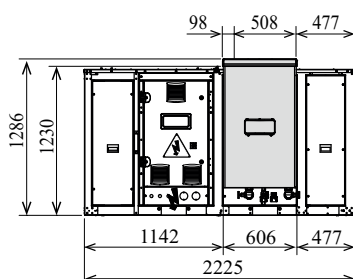
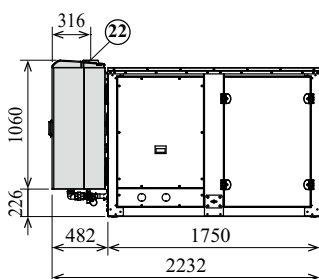
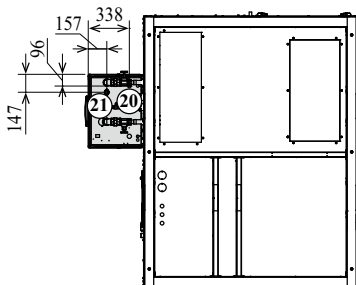

#### Legend

All dimensions are given in mm.

- ⊙20 Boiler drainage Ø 25mm  
**Important: Siphon minimum height 300mm**
- ⊙21 Gas supply 1" M
- ⊙22 Flue outlet (flue connection):  
Condexa PRO 40 / 50 / 70: Ø 80mm



## OPTIONS FOR THE INDOOR CIRCUIT

### 50FF/FC 052-058-062-070-074-086-093-099, "Standard"

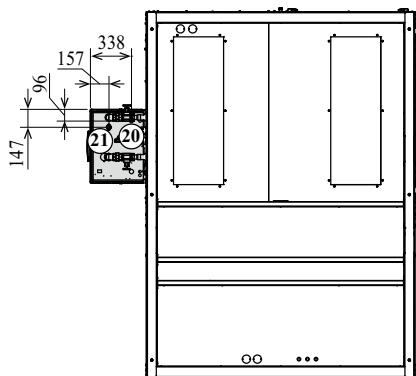

50FF/FC	Dimensions (mm)		
	A	B	C
052 to 062	3.000	1.588	806
070 to 099	3.650	1.858	1.186

#### Legend

All dimensions are given in mm.

- (20) Boiler drainage Ø 25mm  
**Important: Siphon minimum height 300mm**
- (21) Gas supply 1" M
- (22) Flue outlet (flue connection):  
Condexa PRO 50 / 70: Ø 80mm  
Condexa PRO 100: Ø 110 mm

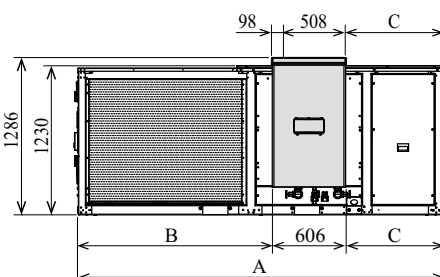
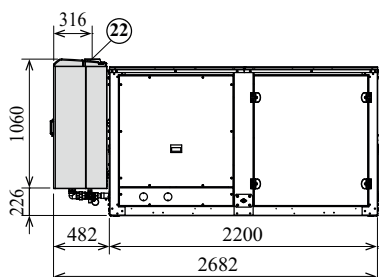

### 50FF/FC 052-058-062-070-074-086-093, "In-line"

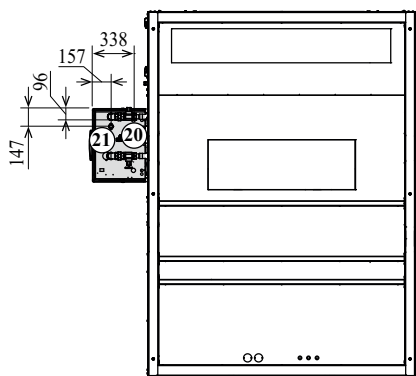

50FF/FC	Dimensions (mm)		
	A	B	C
052 to 062	3.000	1.588	806
070 to 099	3.650	1.860	1.184

#### Legend

All dimensions are given in mm.

- (20) Boiler drainage Ø 25mm  
**Important: Siphon minimum height 300mm**
- (21) Gas supply 1" M
- (22) Flue outlet (flue connection):  
Condexa PRO 50 / 70: Ø 80mm  
Condexa PRO 100: Ø 110 mm

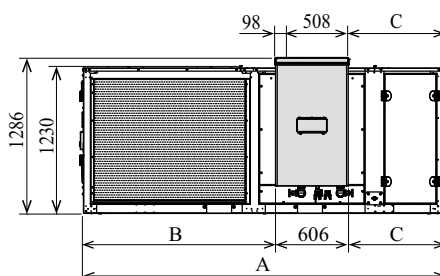
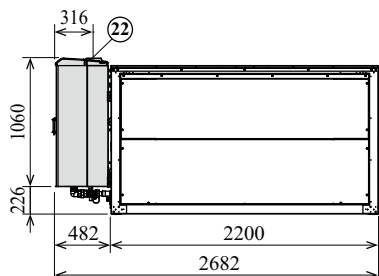

#### NOTES:

- Drawings are not contractually binding.
- Before designing an installation, consult the certified dimensional drawings, available on request.

#### IMPORTANT:

- The flue of the gas boiler is not supplied with the unit. Its design and installation is the responsibility of the installer and must comply with all the directives and regulations in force in the installation location.

## OPTIONS FOR THE INDOOR CIRCUIT

### Auxiliary electrical heaters

Auxiliary electrical heaters, with two power stages and on/off control, for assembly and connection inside the unit.

■ Up to 3 values of total power available for each model:

50FF/FC	020 to 028	037 to 047	052 to 099
RAF (Low)	12 kW	12 kW	18 kW
RAM (Nominal)	18 kW	18 kW	27 kW
RAS (High)	unavailable	27 kW	36 kW

■ Characteristics:

Total power (kW)	12	18	27	36
Stages power (kW)	6 + 6	9 + 9	9 + 18	18 + 18
Current (A)	17,3	26,0	39,0	52,0
Power supply	400 V / III ph			

### Preheater in fresh air (BF assembly)

With BF assembly, 100% fresh air, it is possible to incorporate a preheater module (electrical heater) coupled to the fresh air intake.

This module is supplied in kit for installation on site.

The electrical heater with proportional control will modulate capacity to get the condenser inlet conditions within the operating limits of the cooling circuit in case of very low outdoor temperatures.

■ 2 values of total power available for each model:

50FF/FC	020 to 047	052 to 062	070 to 099
Low power	18 kW	27 kW	36 kW
Nominal power	36 kW	54 kW	72 kW

■ Characteristics:

Total power (kW)	18	27	36	54	72
Current (A)	26,0	39,0	52,0	78,0	104,0
Power supply	400 V / III ph				

### Location of the preheater module

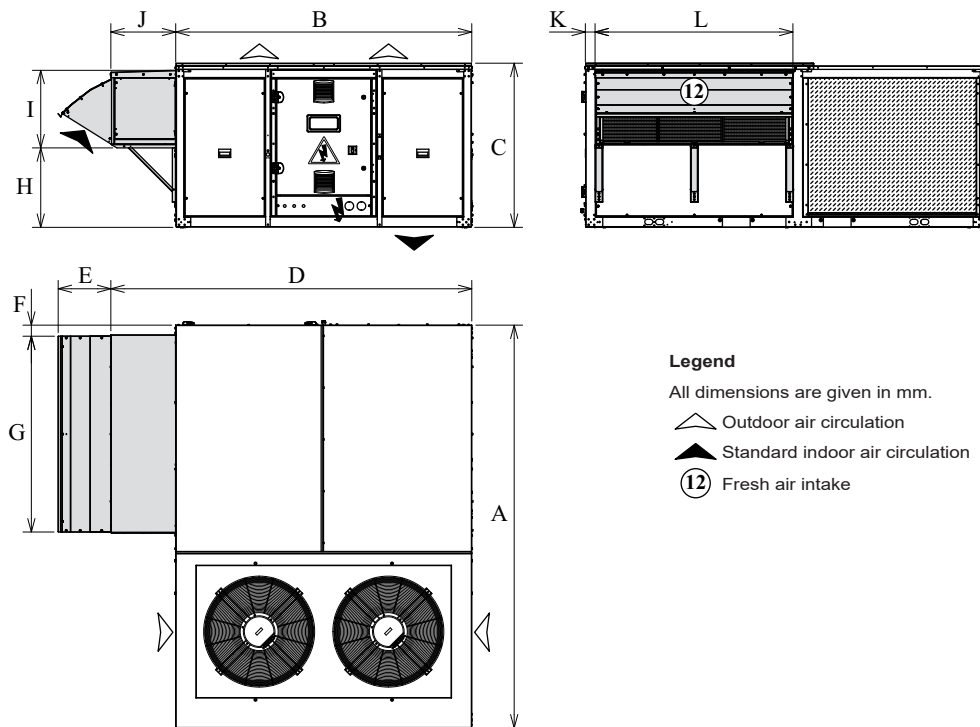

50FF/FC	Dimensions (mm)											
	A	B	C	D	E	F	G	H	I	J	K	L
020 to 047	2.225	1.750	1.230	2.232	391	82	998	591	577	482	73	1.013
052 to 062	3.000	2.200	1.230	2.682	391	82	1.455	591	577	482	72	1.470
070 to 099	3.650	2.200	1.230	2.682	391	82	1.835	591	577	482	72	1.850

### NOTES:

- Drawings are not contractually binding.
- Before designing an installation, consult the certified dimensional drawings, available on request.

## OPTIONS FOR THE INDOOR CIRCUIT

### Operating limits with 100% fresh air unit (BF assembly)

#### ■ COOLING mode:

- The maximum outdoor temperature depends on the air flow. The lower air flow, the higher temperature: 33°C DB with nominal air flow, 35°C DB with minimum air flow and 43°C DB with the minimum air flow of the BF assembly (50% lower than in rest of assemblies).

#### ■ HEATING mode:

- Without electrical preheater: minimum outdoor temperature: 7°C with minimum air flow.
- With electrical preheater: the minimum outdoor temperature depends on the model, the air flow and the selected preheater. Refer to the attached table for reference although, depending on the model, this temperature may be lower.

Minimum outdoor temperature with preheater option	Electrical preheater	
	Low power	Nominal power
Nominal air flow	> 2°C	> -3°C
Minimum air flow of BF assembly	> -6°C	> -15°C

### Active dehumidification

Active dehumidification with extra condensation coil for dehumidification applications in high relative humidity ambients.

Note: this option is not available for the 50FC 099 model.

The dehumidification process is done by the main refrigerant coil, the activation of compressors in cooling mode allows humidity to be removed from the evaporation coil. Depending on temperature conditions in comparison with set-point conditions, the control will adapt the amount of energy recovered in the additional condensation coil to reheat the air flow. This option also allows an additional reheating using the auxiliary electrical heaters.

#### ■ Influence of selection conditions:

Dehumidification capacity of the unit is strongly influence by different factors:

- Supply air flow: The lower air flow, the higher dehumidification capacity.
- Relative humidity setpoint: The influence of humidity setpoint is key. The higher setpoint, the higher dehumidification capacity.

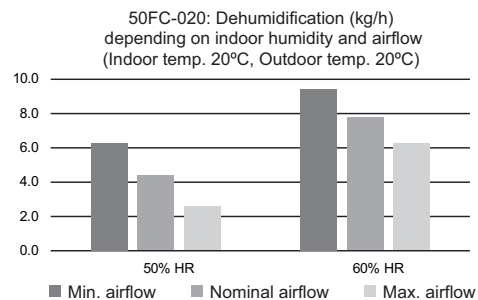

#### ■ Technical performance:

Calculations performed for the minimum supply flow of the unit.

50FF/FC		020	028	037	040	045	047	052	058	062	070	074	086	093
Dehumidification capacity (1)	kg/h	7,0	8,9	9,7	12,4	15,4	17,5	16,9	19,6	21,6	22,3	25,3	31,2	38,4
Energy recovery capacity (1) (4)	kW	28,3	35,2	42,0	46,9	52,6	55,7	33,2	36,3	38,0	42,6	45,3	50,6	56,7
Dehumidification capacity (2)	kg/h	12,3	15,5	17,7	21,1	25,2	27,7	29,3	33,2	35,6	38,5	42,5	50,0	59,4
Energy recovery capacity (2) (4)	kW	30,0	37,5	44,9	50,0	56,1	59,3	35,4	38,7	40,4	45,5	48,3	53,9	60,2
Dehumidification capacity (3)	kg/h	6,2	7,5	7,9	10,4	13,1	15,0	14,1	16,7	18,4	19,4	22,4	26,6	34,2
Energy recovery capacity (3) (4)	kW	25,7	32,5	38,5	43,3	48,4	51,3	30,6	33,5	35,0	38,9	41,4	46,5	51,7

(1) Indoor coil conditions: 27°C and 50%HR. Outdoor temperature 35°C.

(2) Indoor coil conditions: 25°C and 60%HR. Outdoor temperature 20°C.

(3) Indoor coil conditions: 20°C and 50%HR. Outdoor temperature 20°C.

(4) Maximum energy recovery capacity in the additional condensation coil.

Note: Axial 2-speed outdoor fans (optional) are not recommended with active dehumidification and outdoor temperatures below 12°C.

Note: the active dehumidification is not compatible with the hot water coil, the gas boiler, the air zoning, the BF assembly and the 50FC 099 model.

## OPTIONS FOR THE INDOOR CIRCUIT

### Warm air heater module with gas burner

Warm air heater module with gas burner with modulating actuator, in accordance with the Gas Directive 2009/142/EC, installed inside a pre-assembly roofcurb. The 50FF/FC unit with lower air supply will be placed on this roofcurb.

EC certification: 0476CQ0451.

■ Up to 3 values of total power available for each model:

50FF/FC	020 to 047	052 to 062	070 to 099
BAF (Low)	PCH020	unavailable	unavailable
BAM (Nominal)	PCH034	PCH065	PCH080
BAS (High)	PCH045	PCH080	PCH105

Note: the gas burner is not compatible with the heat recovery coil or the active dehumidification.

■ The key features of the boiler are:

- Natural or propane gas burner.
- Condensation boiler with premixing and modulation technology that allows outputs close to 109% (Hi performance).
- The premixed burner, in combination with the air/gas valve, ensures a "clean" combustion. Low NOx emissions < 70 mg/kWh HCV (class 5, according to standard EN 297).  
Note: Burners must not exceed NOx:70mg/kWh HCV emission values from January 1<sup>st</sup>, 2021 (according to European Regulations 2016/2281).
- The combustion chamber and the burner are entirely made of stainless steel.
- Electronic controller with microprocessor and multifunction

LCD display, located inside the burner, for burner's control, configuration and diagnostics.

- The electronic control of the unit will only manage the burner connection as heating support depending on the ambient conditions.

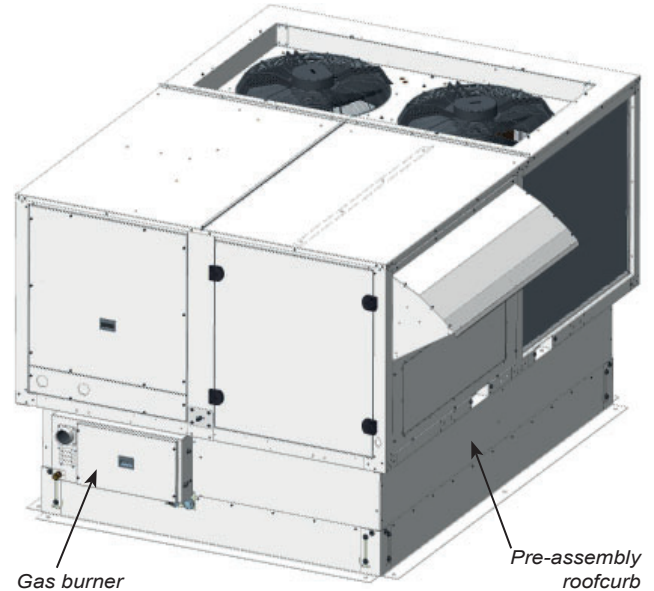

Note: It's recommended to use the clogged filter pressostat (optional) in units with gas burner.

Model			PCH020	PCH034	PCH045	PCH065	PCH080	PCH105						
Type of equipment			B23P - B53P - C13 - C43 - C53 - C63 - C83											
EC certification			PIN.		0476CQ0451									
NOx Class			Val		5									
Heater performance	Range		Min.	Max	Min.	Max	Min.	Max	Min.	Max	Min.	Max	Min.	Max
	Thermal output (Hi)	kW	4,75	19,00	7,60	34,85	8,50	42,00	12,40	65,00	16,40	82,00	21,00	100,00
	Useful thermal output	kW	4,97	18,18	8,13	33,56	8,97	40,45	13,40	62,93	17,77	80,03	22,77	97,15
	Hi performance (L.C.V.)	%	104,63	95,68	106,97	96,30	105,50	96,30	108,06	96,82	108,35	97,60	108,40	97,15
	Hs performance (H.C.V.)	%	94,26	86,20	96,37	86,76	95,07	86,76	97,36	87,22	97,62	87,93	97,68	87,52
	Flue losses with burner on (Hi)	%	0,4	4,3	0,6	3,7	0,5	3,7	0,2	3,2	0,3	2,4	0,2	2,8
	Flue losses with burner off (Hi)	%	<0,1											
	Losses in enclosure (1)		0%											
Max. condensation (2)	l/h	0,4	0,9	1,1	2,1	3,3	2,7							
Exhaust gases - Polluting emissions	Carbon monoxide - B1 - (0% of O <sub>2</sub> ) (3)	ppm	< 5											
	Nitrogen oxides - NOx - (0% of O <sub>2</sub> ) (Hi) (4)		38 mg/kWh - 22 ppm	42 mg/kWh - 24 ppm	33 mg/kWh - 19 ppm	39 mg/kWh - 22 ppm	41 mg/kWh - 23 ppm	39 mg/kWh - 22 ppm						
	Nitrogen oxides - NOx - (0% of O <sub>2</sub> ) (Hs) (5)		34 mg/kWh - 20 ppm	38 mg/kWh - 22 ppm	30 mg/kWh - 17 ppm	35 mg/kWh - 20 ppm	37 mg/kWh - 21 ppm	35 mg/kWh - 20 ppm						
	Available pressure at flue	Pa	80	90	100	120								
Electrical data	Power supply		230 Vac - 50 Hz single-phase											
	Power input		11	45	11	74	24	82	15	97	20	123	20	130
	Power input in stand-by		<5											
	Ingress protection rating		IP X5D											
	Operating Temperatures		from -15°C to +40°C											
Connections	Ø gas connection	GAS	UNI/ISO 7/1- 3/4"											
	Ø intake/exhaust pipes	mm	80/80											

(1) Enclosure losses match those of the machine housing the PCH.

(2) Max. condensation produced acquired from testing 30%Qn.

(3) Value referenced to cat. H (G20)

(4) Weighted value to EN1020:2009 ref. to class H (G20), referred to Hi (L.C.V.).

(5) Weighted value to EN1020:2009 ref. to class H (G20), referred to Hs (H.C.V.).

## OPTIONS FOR THE INDOOR CIRCUIT

### ■ Gas settings:

Gas type	Gas settings	PCH020		PCH034		PCH045		PCH065		PCH080		PCH105	
		min.	max.	min.	max.	min.	max.	min.	max.	min.	max.	min.	max.
G20 Cat. E-H	Air supply pressure	mbar 20 [min 17-max 25]											
	Ø pilot nozzle	mm 0,7											
	Gas consumption (15°C-1013mbar)	0,51	2,01	0,80	3,69	0,90	4,44	1,31	6,88	1,74	8,68	2,22	10,58
	Carbon dioxide - CO <sub>2</sub> content	8,8	9,1	8,7	9,1	8,7	9,1	8,7	9,1	8,7	9,1	8,5	9,1
	Fumes temperature	39	113	31	94	30	94	31	86	26,5	70	28	80
	Fume mass flow rate (max.)	31		57		72		107		135		165	
	Gas butterfly valve	5,8		7,4		7,5		11,0		12,2		15,8	
G25 Cat. L-LL	Air supply pressure	mbar 25 [min 17-max 30] (20 for Germany)											
	Ø pilot nozzle	mm 0,7 (0,75 for Germany)											
	Gas consumption (15°C-1013mbar)	0,59	2,34	0,93	4,29	1,05	5,17	1,53	8,00	2,02	10,1	2,21	12,30
	Carbon dioxide - CO <sub>2</sub> content	8,8	9,0	8,6	9,0	8,8	8,9	8,8	9,2	8,6	8,9	8,8	9,0
	Fumes temperature	39	113	31	94	30	94	31	86	26	70	28	80
	Fume mass flow rate (max.)	kg/h --											
	Gas butterfly valve	7,4		8,9		8,9		Not necessary		Not necessary		Not necessary	
G30 Cat. 3B-P	Air supply pressure	mbar 30 [min 25-max 35] - 50 [min 42,5-max 57,5]											
	Ø pilot nozzle	mm 0,51											
	Gas consumption (15°C-1013mbar)	0,40	1,58	0,63	2,90	0,71	3,49	1,03	5,39	1,49	6,80	1,70	8,30
	Carbon dioxide - CO <sub>2</sub> content	10,8	11,4	10,8	11,5	10,8	10,9	10,7	11,3	10,1	10,3	10,4	10,6
	Fumes temperature	39	113	31	94	30	94	31	86	26,5	70	28	80
	Fume mass flow rate (max.)	kg/h --											
	Gas butterfly valve	3,7		5,0		5,2		6,5		7,0		9,3	
G31 Cat. 3P	Air supply pressure	mbar 30 [min 25-max 35] - 37 [min 25-max 45] - 50 [min 42,5-max 57,5]											
	Ø pilot nozzle	mm 0,51											
	Gas consumption (15°C-1013mbar)	0,39	1,55	0,62	2,85	0,70	3,43	1,01	5,31	1,34	6,70	1,47	8,18
	Carbon dioxide - CO <sub>2</sub> content	9,3	9,8	9,2	9,7	9,3	9,4	9,4	9,6	9,3	9,6	9,5	9,8
	Fumes temperature	39	113	31	94	30	94	31	86	26,5	70	28	80
	Fume mass flow rate (max.)	24		45		58		84		107		130	
	Gas butterfly valve	3,7		5,0		5,2		6,5		7,0		9,3	

### ■ Type of gas used depending on the destination country:

Country	Category	Gas	Pressure (mbar)	Gas	Pressure (mbar)
Austria, Switzerland	II2H3B/P	G20	20	G30/G31	50
Belgium < 70kW	I2E(S)B,I3P	G20/G25	20/25	G31	37
Belgium > 70kW	I2E(R)B,I3P	G20/G25	20/25	G31	37
Germany	II2ELL3B/P	G20/G25	20	G30/G31	50
Denmark, Finland, Greece, Sweden, Norway, Italy, Czech Republic, Estonia, Lithuania, Slovenia, Albania, Macedonia, Bulgaria, Romania, Croatia, Turkey, Azerbaijan	II2H3B/P	G20	20	G30/G31	30
Spain, United Kingdom, Ireland, Portugal, Slovakia	II2H3P	G20	20	G31	37
France	II2Esi3P	G20/G25	20/25	G31	37
Luxembourg	II2E3P	G20/G25	20	G31	37/50
Netherlands	II2EK3B/P	G20/G25.3	20/25	G30/G31	30
Hungary	II2HS3B/P	G20/G25.1	25	G30/G31	30
Cyprus, Malta	I3B/P	--	--	G30/G31	30
Latvia	I2H	G20	20		
Iceland	I3P	--	--	G31	37
Poland	II2ELwLs-3B/P	G20/G27/G2.350 (*)	20/13	G30/G31	37
Russia	II2H3B/P	G20	20	G30/G31	30

(\*) Consult the available burners with G2.350.

## OPTIONS FOR THE INDOOR CIRCUIT

### Heat recovery coil

The function of the heat recovery coil is to pre-heat the air that will pass through the main indoor coil. For this, it uses the temperature of an outdoor water installation. This function is managed by the unit's electronic control.

The coil is supplied with a 3-way valve for installation outside the unit but manages by the unit's electronic control.

This option is compatible with B1, B2, BF, BT, BB, R1 and R2 assemblies.

50FF/FC		020	028	037	040	045	047	052	058	062	070	074	086	093	099
Air pressure drop (mm.w.c.)		2,6	3,9	5,0	5,5	5,7	5,7	4,3	4,6	4,6	4,5	4,5	4,7	4,7	5,5
Water 35/30°C (30% MEG) and inlet air 20°C	Heating capacity (kW)	11,20	13,00	17,02	17,52	17,76	17,76	23,67	24,62	24,62	32,77	32,77	33,37	33,37	35,77
	Water flow (m³/h)	2,08	2,42	3,16	3,26	3,30	3,30	4,40	4,57	4,57	6,08	6,08	6,20	6,20	6,68
	Water pressure drop (m.w.c.)	2,7	3,1	4,4	4,5	4,6	4,6	3,4	3,5	3,5	5,5	5,5	5,6	5,6	6,0
Water 35/30°C (30% MEG) and inlet air 15°C	Heating capacity (kW)	16,89	19,64	25,26	26,19	26,52	26,52	35,62	36,50	36,50	48,54	48,54	49,42	49,42	52,94
	Water flow (m³/h)	3,14	3,65	4,69	4,87	4,93	4,93	6,61	6,77	6,77	9,01	9,01	9,17	9,17	9,81
	Water pressure drop (m.w.c.)	4,1	4,8	7,3	7,7	7,8	7,8	5,4	5,6	5,6	9,7	9,7	9,9	9,9	10,7

Water (inlet air 20°C)	30/35°C	*/40°C	*/45°C	% of MEG	10%	20%	30%
Correction coefficients	1,00	1,35	1,70	Correction coefficients	1,06	1,03	1,00

Note: the heat recovery coil is not compatible with the hot water coil, the gas boiler or the gas burner.

### Position of the hydraulic connections of the heat water coil

**“Standard” assemblies**

① Outlet ② Inlet

50FF/FC	Dimensions (mm)			
	A	B	C	Ø
020 to 047	872	721	443	1/2"
052 to 062	1099	721	443	1/2"
070 to 099	1099	721	443	3/4"

**“In-line” assemblies**

① Outlet ② Inlet

50FF/FC	Dimensions (mm)			
	A	B	C	Ø
052 to 062	534	721	443	1/2"
070 to 093	914	721	443	3/4"

### Droplet eliminator after the indoor air coil

Air flow at which it is recommended to install a droplet eliminator after the indoor coil.

50FF/FC	020	028	037	040	045	047	052	058	062	070	074	086	093	099
Air flow (m³/h)	7.776	7.776	10.206	10.206	10.206	10.206	14.580	14.580	14.580	18.468	18.468	18.468	18.468	18.468

Note: for operating conditions with high dehumidification in the indoor coil (e.g. in installations close to the coast) it may be necessary to install a separator even if the flow is less than the previous one.

Note: the droplet eliminator after the indoor coil is not compatible with the hot water coil or the gas boiler.



## WEIGHT OVERVIEW

### Weight overview of the various assemblies (kg)

50FF		020	028	037	040	045	047	052	058	062	070	074	086	093
B1 assembly		594	617	699	698	704	701	914	929	936	1.035	1.059	1.057	1.078
B2 and BF assemblies		609	632	718	718	718	720	946	967	969	1.070	1.094	1.112	1.113
B3 assembly		682	705	796	796	796	798	1.047	1.062	1.070	1.197	1.221	1.230	1.231
BX assembly		713	736	815	815	815	817	1.090	1.111	1.112	1.248	1.272	1.290	1.291
BP assembly		723	746	831	831	828	833	1.120	1.141	1.142	1.276	1.300	1.309	1.310
BA assembly		781	804	900	900	897	902	1.211	1.232	1.233	1.379	1.403	1.412	1.413
BT assembly		774	797	882	882	882	884	1.213	1.228	1.236	1.371	1.395	1.413	1.414
BB assembly		832	855	951	951	951	953	1.304	1.319	1.327	1.474	1.498	1.516	1.517
BW assembly	Machine	722	745	834	834	834	837	1.122	1.143	1.145	1.206	1.230	1.248	1.249
	Recovery module	254	254	254	254	254	254	348	348	348	454	454	454	454
	Total weight	976	999	1.088	1.088	1.088	1.091	1.470	1.491	1.493	1.660	1.684	1.702	1.703
R1 assembly		--	--	--	--	--	--	972	993	994	1.068	1.092	1.111	1.111
R2 assembly		--	--	--	--	--	--	1.010	1.031	1.033	1.105	1.129	1.147	1.148
RP assembly		--	--	--	--	--	--	1.180	1.201	1.202	1.294	1.318	1.336	1.337
RW assembly	Machine	--	--	--	--	--	--	957	978	980	1.247	1.271	1.289	1.290
	Recovery module	--	--	--	--	--	--	719	719	719	454	454	454	454
	Total weight	--	--	--	--	--	--	1.676	1.697	1.699	1.701	1.725	1.743	1.744

50FC		020	028	037	040	045	047	052	058	062	070	074	086	093	099
B1 assembly		594	617	699	698	704	701	986	986	1.004	1.146	1.146	1.135	1.160	1.186
B2 and BF assemblies		609	632	718	718	718	720	1.018	1.024	1.037	1.181	1.181	1.190	1.195	1.221
B3 assembly		682	705	796	796	796	798	1.119	1.119	1.138	1.308	1.308	1.308	1.313	1.339
BX assembly		713	736	815	815	815	817	1.162	1.168	1.180	1.359	1.359	1.368	1.373	1.399
BP assembly		723	746	831	831	828	833	1.192	1.198	1.210	1.387	1.387	1.387	1.392	1.418
BA assembly		781	804	900	900	897	902	1.283	1.289	1.301	1.490	1.490	1.490	1.495	1.521
BT assembly		774	797	882	882	882	884	1.285	1.285	1.304	1.482	1.482	1.491	1.496	1.522
BB assembly		832	855	951	951	951	953	1.376	1.376	1.395	1.585	1.585	1.594	1.599	1.625
BW assembly	Machine	722	745	834	834	834	837	1.194	1.200	1.213	1.317	1.317	1.326	1.331	1.357
	Recovery module	254	254	254	254	254	254	348	348	348	454	454	454	454	454
	Total weight	976	999	1.088	1.088	1.088	1.091	1.542	1.548	1.561	1.771	1.771	1.780	1.785	1.811
R1 assembly		--	--	--	--	--	--	1.044	1.050	1.062	1.179	1.179	1.189	1.193	--
R2 assembly		--	--	--	--	--	--	1.082	1.088	1.101	1.216	1.216	1.225	1.230	--
RP assembly		--	--	--	--	--	--	1.252	1.258	1.270	1.405	1.405	1.414	1.419	--
RW assembly	Machine	--	--	--	--	--	--	1029	1035	1048	1358	1358	1367	1372	--
	Recovery module	--	--	--	--	--	--	719	719	719	454	454	454	454	--
	Total weight	--	--	--	--	--	--	1.749	1.755	1.767	1.812	1.812	1.822	1.826	--



# WEIGHT OVERVIEW

## Weight supplement from the main options (kg)

50FF/FC		020	028	037	040	045	047	052	058	062	070	074	086	093	099
Pre-assembly roofcurb (without gas burner)		145	145	145	145	145	145	205	205	205	237	237	237	237	237
Pre-assembly roofcurb (with gas burner)	BAF (Low)	265	265	265	265	265	265	--	--	--	--	--	--	--	--
	BAM (Nominal)	274	274	274	274	274	274	385	385	385	463	463	463	463	463
	BAS (High)	284	284	284	284	284	284	411	411	411	483	483	483	483	483
Electrical heaters	RAF (Low)	20	20	20	20	20	20	17	17	17	17	17	17	17	17
	RAM (Nominal)	17	17	17	17	17	17	21	21	21	21	21	21	21	21
	RAS (High)	--	--	21	21	21	21	25	25	25	25	25	25	25	25
Hot water coil	Standard	Empty	33	33	37	37	37	37	51	51	51	58	58	58	58
		Service	40	40	46	46	46	46	67	67	67	78	78	78	78
	Very low outdoor T	Empty	41	41	45	45	45	45	71	71	71	78	78	78	78
		Service	49	49	55	55	55	55	89	89	89	100	100	100	100
Boiler + Hot water coil	Boiler		69	69	69	69	69	69	69	69	69	69	69	69	69
	Water circuit	Empty	47	47	52	52	52	52	79	79	79	87	87	87	87
		Service	55	55	62	62	62	62	98	98	98	109	109	109	109
Total service weight		124	124	131	131	131	131	167	167	167	178	178	178	178	178
Heat recovery coil (HRC)	Empty		22	22	21	21	21	21	30	30	30	36	36	36	36
	Service		31	31	31	31	31	31	44	44	44	53	53	53	53
Preheater in fresh air	Low power		93	93	93	93	93	93	121	121	121	144	144	144	144
	Nominal power		105	105	105	105	105	105	138	138	138	165	165	165	165
Supply fan	Low pressure (F)		-7	-7	--	--	--	--	-21	-21	-21	--	--	-9	-9
	Nominal pressure, aluminium (M)		4	4	8	8	8	8	9	9	9	9	9	0	0
	High pressure (S)		4	4	28	28	28	28	38	38	38	29	29	29	29
Droplet eliminator	Indoor coil		24	24	25	25	25	25	34	34	34	43	43	43	43
	Fresh air intake		8	8	8	8	8	8	11	11	11	14	14	14	14
Filters	G4 l.p.d.		2	2	2	2	2	2	2	2	2	3	3	3	3
	G4 + M6		6	6	6	6	6	6	9	9	9	11	11	11	11
	G4 + F7 // G4 + F9		6	6	6	6	6	6	9	9	9	12	12	12	12
	G4 l.p.d. + F7 // G4 l.p.d. + F9		7	7	7	7	7	7	11	11	11	14	14	14	14
	M6 + F7 // M6 + F9		8	8	8	8	8	8	13	13	13	17	17	17	17
	F7 + F9 // F9 + F9		9	9	9	9	9	9	13	13	13	17	17	17	17
Centrifugal return fan (BT and BB assemblies)	A: Low flow + nominal pressure		-8	-7	7	10	10	10	-21	-21	-21	20	20	20	20
	B: Low flow + high pressure		-1	3	31	31	31	31	0	10	10	30	30	30	30
	C: Nominal flow + nominal pressure		-7	7	13	17	17	17	-1	-1	-1	47	47	47	47
	D: Nominal flow + high pressure		3	9	38	38	38	38	26	26	26	145	145	145	145
	E: High flow + nominal pressure		0	13	17	36	36	36	20	27	27	60	60	60	60
	F: High flow + high pressure		9	15	48	63	48	48	44	44	44	145	145	185	185
	G: Low flow + low pressure		-10	-2	1	7	7	7	-2	-2	-2	10	10	-2	-2
	H: Nominal flow + low pressure		-2	7	8	34	35	35	3	3	3	14	14	14	14
	I: High flow + low pressure		1	7	34	40	40	40	21	21	21	56	56	56	56
Return plug-fan	BP, BA, RP assemblies		3	3	3	3	3	3	6	6	6	6	6	6	6
	BT, BB assemblies		3	3	3	3	3	3	--	--	--	6	6	6	6
	BW, RW assemblies		3	3	0	0	0	0	--	--	--	0	0	0	0
Active dehumidification	50FF series		27	27	34	34	34	34	52	52	52	59	59	59	--
	50FC series		38	38	45	45	45	45	59	59	59	70	70	70	--

## RECOMMENDED SERVICE CLEARANCE

### 50FF/FC 020-028-037-040-045-047: B1, B2 and BF assemblies

50FF/FC	Overall dimension (mm)			Service clearance (mm)			
	Length	Width	Height	A	B	C	D
020 to 047	2.225	1.750	1.230	1.200	1.000	1.000	1.600

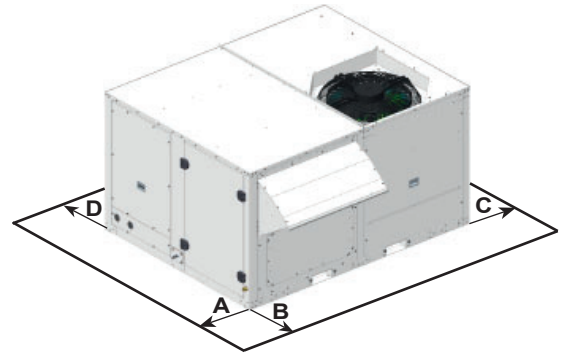

### 50FF/FC 020-028-037-040-045-047: B3, BX, BP and BA assemblies

50FF/FC	Overall dimension (mm)			Service clearance (mm)			
	Length	Width	Height	A	B	C	D
020 to 047	2.230	1.755	1.905	1.200	1.000	1.000	1.600

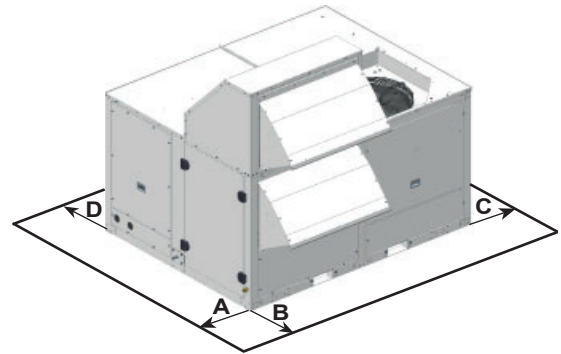

### 50FF/FC 020-028-037-040-045-047: BT and BB assemblies

50FF/FC	Overall dimension (mm)			Service clearance (mm)			
	Length	Width	Height	A	B	C	D
020 to 047	2.230	1.760	1.975	1.200	1.000	1.000	1.600

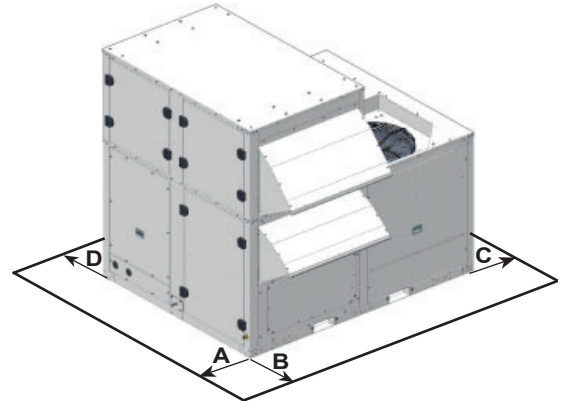

### 50FF/FC 020-028-037-040-045-047: BW assembly

50FF/FC	Overall dimension (mm)			Service clearance (mm)			
	Length	Width	Height	A	B	C	D
020 to 047	2.230	2.565	1.905	1.200	1.000	1.000	1.600

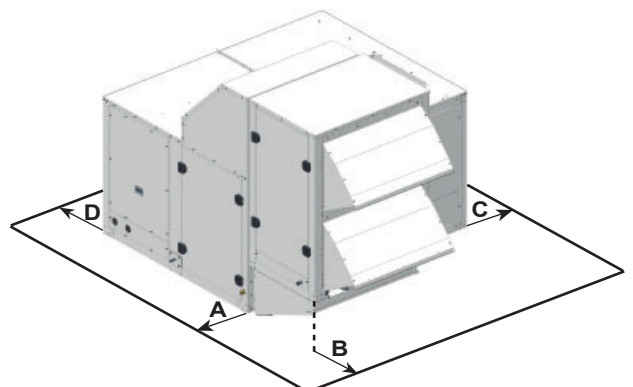

**NOTE:**

- Unit not designed to have overhead obstruction.

## RECOMMENDED SERVICE CLEARANCE

### 50FF/FC 052-058-062-070-074-086-093-099: B1, B2 and BF assemblies

50FF/FC	Overall dimension (mm)			Service clearance (mm)			
	Length	Width	Height	A	B	C	D
052 to 062	3.000	2.200	1.230	1.600	1.000	1.000	1.000
070 to 099	3.655	2.200	1.230	2.000	1.000	1.000	1.000

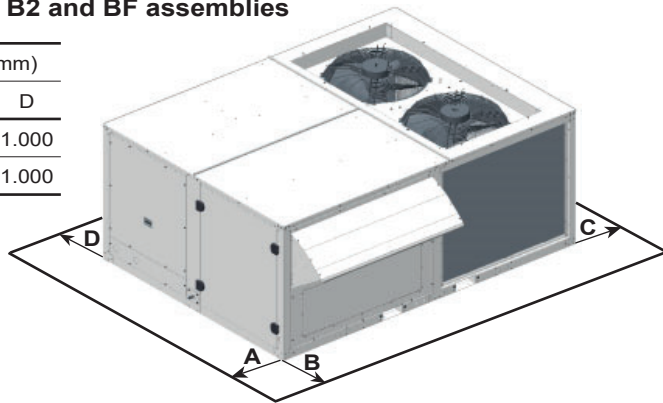

### 50FF/FC 052-058-062-070-074-086-093-099: B3, BX, BP and BA assemblies

50FF/FC	Overall dimension (mm)			Service clearance (mm)			
	Length	Width	Height	A	B	C	D
052 to 062	3.000	2.205	1.905	1.600	1.000	1.000	1.000
070 to 099	3.655	2.205	1.905	2.000	1.000	1.000	1.000

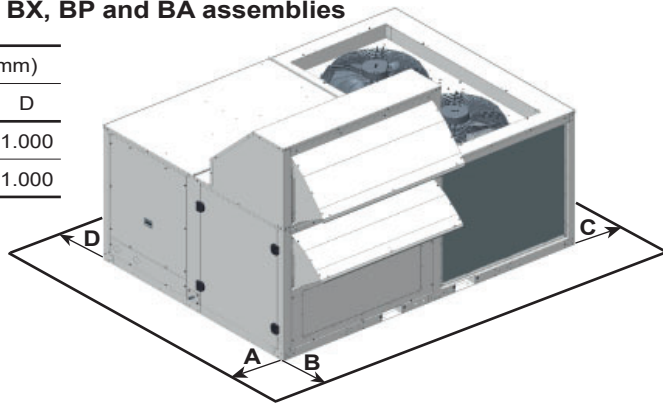

### 50FF/FC 052-058-062-070-074-086-093-099: BT and BB assemblies

50FF/FC	Overall dimension (mm)			Service clearance (mm)			
	Length	Width	Height	A	B	C	D
052 to 062	3.000	2.210	1.995	1.600	1.000	1.000	1.000
070 to 099	3.655	2.210	1.995	2.000	1.000	1.000	1.000

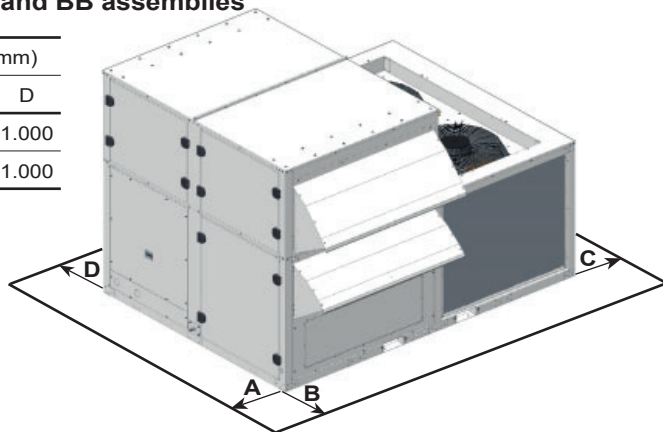

### 50FF/FC 052-058-062-070-074-086-093-099: BW assembly

50FF/FC	Overall dimension (mm)			Service clearance (mm)			
	Length	Width	Height	A	B	C	D
052 to 062	3.000	3.015	1.905	1.600	1.000	1.000	1.000
070 to 099	3.655	3.015	1.905	2.000	1.000	1.000	1000

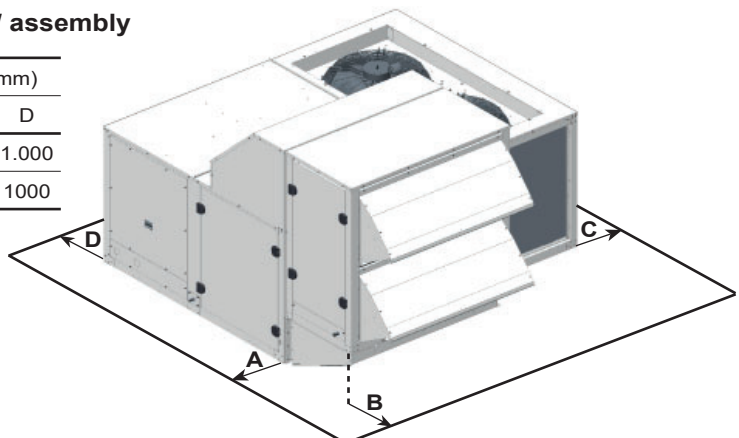

**NOTE:**

- Unit not designed to have overhead obstruction.

## RECOMMENDED SERVICE CLEARANCE

### 50FF/FC 052-058-062-070-074-086-093: R1 and R2 assemblies

50FF/FC	Overall dimension (mm)			Service clearance (mm)			
	Length	Width	Height	A	B	C	D
052 to 062	3.000	2.200	1.230	1.000	1.000	1.300	2.200
070 to 093	3.650	2.200	1.230	1.000	1.000	1.600	2.200

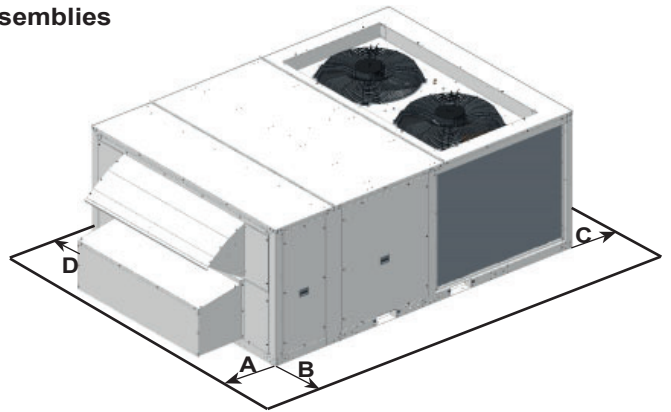

### 50FF/FC 052-058-062: RP assembly

50FF/FC	Overall dimension (mm)			Service clearance (mm)			
	Length	Width	Height	A	B	C	D
052 to 062	3.865	2.200	1.230	1.000	1.000	1.300	2.200

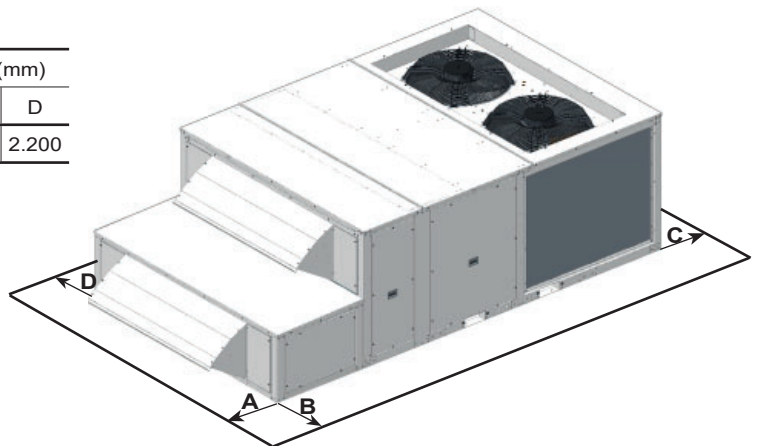

### 50FF/FC 070-074-086-093: RP assembly

50FF/FC	Overall dimension (mm)			Service clearance (mm)			
	Length	Width	Height	A	B	C	D
070 to 093	3.655	2.210	1.905	1.000	1.000	1.600	2.200

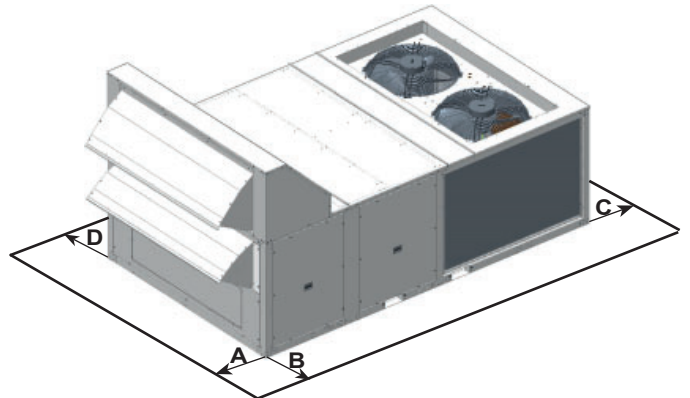

### 50FF/FC 052-058-062-070-074-086-093: RW assembly

50FF/FC	Overall dimension (mm)			Service clearance (mm)			
	Length	Width	Height	A	B	C	D
052 to 062	4.675	2.210	1.905	1.000	1.000	1.300	2.200
070 to 093	4.465	2.210	1.905	1.000	1.000	1.600	2.200

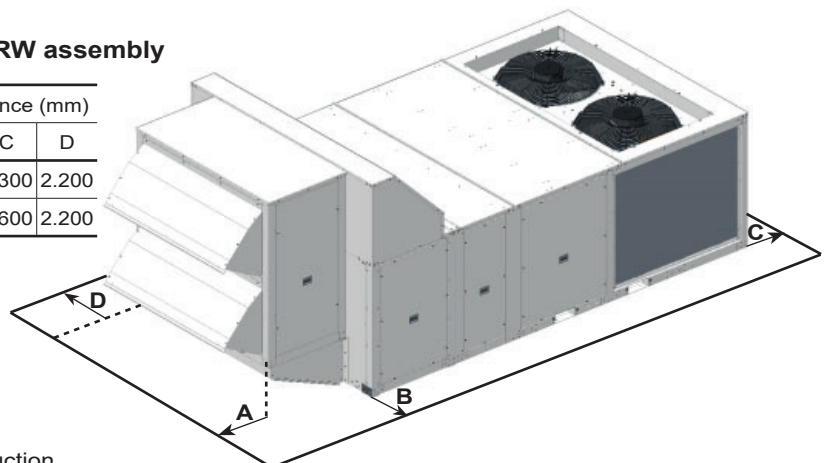

**NOTE:**

- Unit not designed to have overhead obstruction.