

**INSTALLATION OPERATION
AND MAINTENANCE
MANUAL FOR:-**

***MOGENSEN
VIBRATORY PLANT***

MACHINE TYPE: - SPL 1600/2700-L426

SERIAL NUMBER: - 268020A

The information contained herewith is issued as a guide and is not intended to be definitive. All reference to technical and commercial information herein is subject to our Conditions of Sale and gaining written confirmation from ourselves.

Mogensen, A Division of Grantham Engineering Limited, Harlaxton Road, Grantham, Lincolnshire,
England NG31 7SF

Tel. No. +44 (0) 1476 566301 Fax. No. +44 (0) 1476 590145 Web. www.mogensen.co.uk



INDEX

Page 2 -	EC Declaration of Conformity	
Page 3 -	Introduction	
Page 4 -	Mechanical Considerations	
Page 6 -	Electrical Considerations (Also see separate vibratory motor manual at the rear of this manual)	
Page 8 -	Vibrator Starters	
Page 10 -	Typical Control Panel Schematic – Single Vibrator	
Page 11 -	Typical Control Panel Schematic – Twin Vibrator	
Page 12 -	Maintenance Considerations	
Page 13 -	Process Guidelines	
Page 14 -	General Adjustments	
Page 16 -	Tensioning of Screen Meshes	
	i. Side Tensioned Screen Decks	- Page 16
	ii. End Tensioned Screen Decks	- Page 18
	iii. Bolted Screen Decks – design 1	- Page 20
	iv. Bolted Screen Decks – design 2	- Page 21
	v. Bolted Screen Decks – design 3	- Page 22
	vi. Polyurethane Screen Decks	- Page 23
	vii. Forged Steel Tine Decks	- Page 24
	viii. Fabricated Steel Finger Decks	- Page 26
Page 27 -	Isolation Mountings	
Page 29 -	Installation Check List	
Page 31-	Equipment Handling, Decommissioning, Dismantling & Disposal	
Page 32-	Fault Finding Guide	
Page 36-	General Ass/Installation Drawing	Drawing No. SPH/43219
Page 37-	Actual Control Panel Schematic	Drawing No. - PANEL NOT SUPPLIED
Page 38-	Test Certificate	
Page 39-	Additional Manuals / Notes	

EC DECLARATION OF CONFORMITY

Manufacturer:

Mogensen

A Division of Grantham Engineering Ltd
Harlaxton Road
Grantham
Lincolnshire
NG31 7SF
Tel +44 (0) 1476 566301
Fax +44 (0) 1476 590145
www.mogensen.co.uk

Hereby declares that the equipment detailed below conforms to the provisions of the Essential Health and Safety Requirements of the European Machinery Directive 2006/42/EC and also the Supply of Machinery (Safety) Regulations 2008 (SI/2008/1597:

Vibratory:

Mogensen Type: SPL 1600/2700-L426
Serial Number: 268020A

The following harmonised standards have been applied:
EN ISO 12100:2010.



Authorised Person: HDT Williams Title: Technical Director

Signature: 

Date of issue: August 2012 Issue B:

INTRODUCTION

The range of vibratory equipment produced by Mogensen is quite extensive; all are powered by the Invicta vibrator which supplies the motive forces necessary for the equipment to perform its function.

These instructions are for general guidance covering a range of vibratory feeders, conveyors and screen feeders; all are powered by the Invicta vibrator which supplies the motive forces necessary for the equipment to perform its function.

Two types of motion are employed.

CIRCULAR MOTION

This is achieved from a single Invicta Vibrator and is generally applied to certain types of feeder i.e. SR1 range and the RS range of conventional vibrating screens. In order to promote flow, it is usual to have the machine declined and the Vibrator rotating 'with flow'. Only in exceptional circumstances is it possible to run the Vibrator 'counter-flow'.

LINEAR MOTION

Twin vibrators counter rotating will give a linear motion, this type of motion is used when it is required to transport the material horizontally i.e. with vibrating feeders or tubular conveyors, or when it is necessary to control the feed rate by variable speed controllers and when required to create the desired motion necessary when compacting materials i.e. when vibrating tables, beams etc. .

To identify the machine model and serial number it is necessary to look at the Mogensen name-plate attached to the body of the machine; to identify the model of vibratory motor fitted to the machine it is necessary to look at the name plate located on the motors.

The following section will provide basic descriptions of some of the vibratory plant covered by this manual.

MECHANICAL CONSIDERATIONS

GENERAL REQUIREMENTS

When installing vibratory equipment, care should be taken to ensure that all vibrating parts have an adequate clearance from associated plant and steelwork. In general, 30 mm - 50 mm clearance is quite satisfactory but allowance must be made for deflection of the coil springs under no load and loaded conditions. All dust-proofing connections, when used, must be suitably flexible otherwise the efficient operation of the equipment will be impaired.

The attachment of additional parts to the vibratory machine could result in invalidation of any warranty issued with the machine; if additions are required, please consult Mogensen, when we shall be pleased to advise.

ON NO ACCOUNT SHOULD ONE OF A PAIR OF VIBRATORS BE ALLOWED TO RUN ON ITS OWN OR THE VIBRATING MACHINE MAY BE DAMAGED.

Where we supply fixed speed starters or Variable Speed Control, these are complete with all necessary overload protection in the control boxes.

ALL ELECTRICAL CONNECTIONS MUST BE STRONG AND FLEXIBLE TO STAND UP TO VIBRATORY CONDITIONS.

When equipment fitted with twin vibrators are correctly wired, the vibrators should contra-rotate, i.e. when viewed end on, one vibrator should be running clockwise and the other anti-clockwise.

When vibratory equipment leaves our factory the vibrator weights are pre-set; the weights can be adjusted to give a reduced output where this is required.

Where vibrators have been supplied at a pre-set below 100%, please consult with Mogensen before increasing the force output above the factory setting.

IT IS IMPORTANT THAT A PAIR OF VIBRATORS HAVE THEIR WEIGHTS SET TO THE SAME POSITION BOTH ENDS, OTHERWISE THE VIBRATOR(S) AND EQUIPMENT MAY BE DAMAGED.

ADDITIONAL REQUIREMENTS - VIBRATORY SCREENS

It is advisable when arranging the installation of the vibratory screen to allow for adjustment of declination of between 10deg and 20deg where possible, since the angle of decline can have a considerable effect on the efficiency of screening and on the throughput of the screen.

The supporting steelwork should be designed to avoid resonance with the screen frequency of vibration. Care must be taken to ensure the spring mounting positions are accurately set out to avoid misalignment of the springs, which could cause premature failure.

THE ATTACHMENT OF ADDITIONAL PARTS TO THE SCREEN SHOULD NOT BE UNDERTAKEN. IF ANY ADDITIONS MUST BE MADE, PLEASE CONSULT MOGENSEN WHEN WE SHALL BE PLEASED TO ADVISE.

With screens handling material of large particle sizes, it is important that the material is directed onto the feed-on chute liner plate (if fitted). This will prevent excessive wear to the screen cloth.

Wiring up of the majority of screens is normally done from overhead and the terminal box on the vibrator is positioned to suit this method.

Where the equipment is supplied for operating in the horizontal plane, it is essential to check that the machine is level both on its length and its width. Shim the spring seating brackets or supports to ensure this is correct.

ELECTRICAL CONSIDERATIONS

TWIN VIBRATOR APPLICATIONS

Machines powered by twin vibrators require a twin vibrator starter giving individual overload protection to each vibrator and linked to cut out both vibrators if one fails or overloads.

Some form of electrical braking e.g. phase reversal or D.C. injection, is required to minimise excessive movement during stopping.

Thermistor beads are embedded in the vibrator windings, these can be connected to a suitable control device to disconnect the electrical supply in the event of over temperature occurring or a mechanical circuit failure.

The twin vibrator starter panel must have an automatic cut-out feature which protects both vibrators if one should fail.

The equipment and cabling should be selected and installed in accordance with EN61241-14:2004.

The vibrators or vibrator fitted to the machine must be connected to a suitable supply, as stated on the vibrator name plate.

In twin motor applications, the vibrators must always rotate in opposite directions. If they do not, 2 phases on the input line to one of the vibrators must be reversed; one end cap from each of the vibrators should be removed to check the direction of rotation.

The two vibrators must start simultaneously.

In order to ensure simultaneous starting of both vibrators a twin vibrator starter panel must be incorporated. Care must be taken to ensure that the 4 pairs of out of balance weights are set exactly the same and that the two pairs of weights in a given vibrator are lined up exactly with each other and clamped tightly.

FAILURE TO OPERATE THE VIBRATORS CORRECTLY WILL INVALIDATE ALL GUARANTEES.

If one vibrator of a pair is started before the other, or if one vibrator only of a pair is powered, the bearings in the non-powered vibrator will be damaged within a very short time.

If the vibrators rotate in the same direction or if only one vibrator is powered, inadequate vibration will be obtained.

A wiring diagram for a suitable twin vibrator starter is shown within these instructions. For further information on recommended cable sizes and current draws, see the installation and maintenance manual for the Invicta Vibratory motors.

WIRING - TWIN VIBRATOR APPLICATION

THE ELECTRICAL INSTALLATION SHOULD BE PERFORMED GENERALLY BY SUITABLY QUALIFIED PERSONNEL TO INTERNATIONAL STANDARD EN60204 - SAFETY OF MACHINERY – ELECTRICAL EQUIPMENT OF MACHINES.

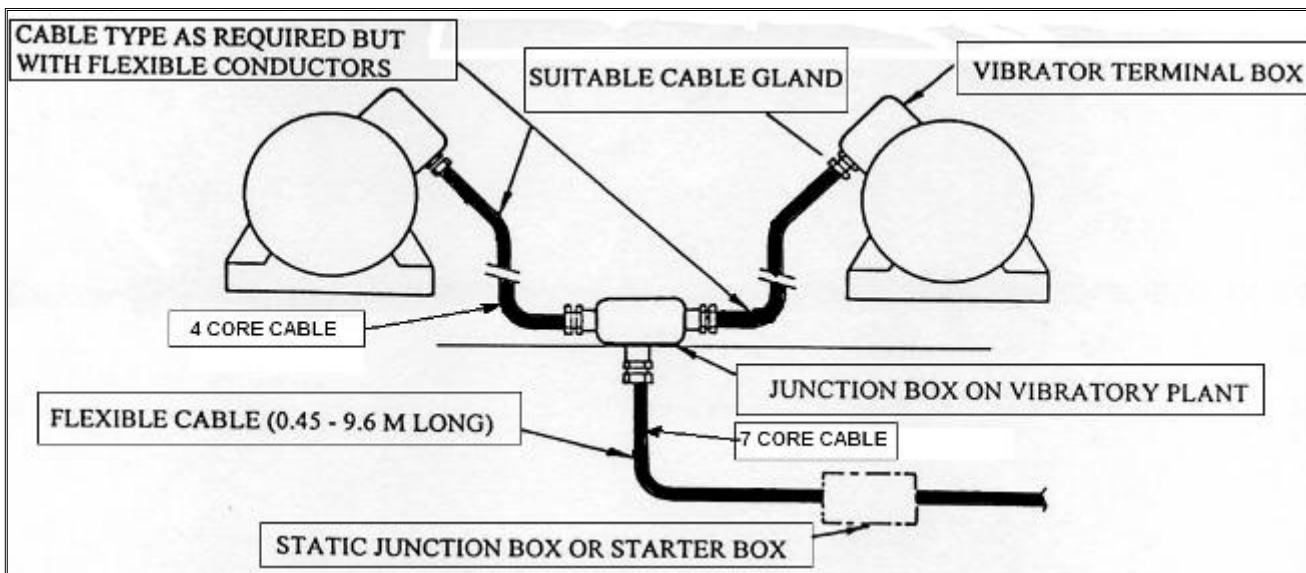

The above diagram is an example of a wiring system suitable for the vibrators.

Where it is not possible to have a junction box on the plant itself, the box may be sited elsewhere or the vibrators wired directly to the control panel.

- 1. ALL CONNECTIONS TO THE VIBRATOR TERMINAL BOX ARE TO BE TIGHTLY MADE TO THE TERMINAL POSTS WITH CRIMPED ON RING TERMINALS.**
- 2. FLEXIBLE CABLES ARE TO BE USED BETWEEN STATIC JUNCTION BOX AND VIBRATOR OR VIBRATORY PLANT JUNCTION BOX.**
- 3. CABLE TO VIBRATOR OR VIBRATORY PLANT FROM STATIC JUNCTION BOX TO HAVE FLEXIBLE CONDUCTORS TYPE 24/0.20 (03), 50/0.25 (05-40), 56/0.30 (45-50) & 80/0.40 (60-75).**
- 4. TWIN VIBRATOR APPLICATIONS SHOULD HAVE A TWIN VIBRATOR STARTER WITH INDIVIDUAL OVERLOADS AND RUNNING INTERLOCK.**

INVICTA SERIES VIBRATOR STARTERS

The Invicta Vibrator Starters has been designed as a reliable and economic starter for use with the "Invicta" range of Vibrators and vibrating equipment.

DESIGN CONSIDERATIONS

The enclosures and the electrical components contained therein have been especially chosen to meet the exact electrical and environmental requirements for vibratory equipment and to give full protection to the Vibrator against overload.

OVERLOAD PROTECTION

Each Starter is fitted with separate overload protection for each Vibrator. The overload unit fitted gives protection against over current dependent on the overload setting, with an accelerated trip in the event of a phase failure. The overload characteristic is temperature compensated over the range of -5 degrees to +60 degrees C.

THE OVERLOADS SHOULD BE SET TO THE F.L.C STATED ON THE MOTOR NAME PLATES, UNDER NO CIRCUMSTANCES SHOULD THESE BE SET ABOVE THIS LEVEL.

REVERSE PHASE BRAKING

The starter includes reverse phase braking this operates by reversing two phases on both motors throwing the motors in reverse. When the stop button is pressed the phases are reversed to the motors for a period of time, this is controlled by timer (T1), when correctly adjusted, the timer will cut the power to the motors, just before their actual direction of rotation is reversed, hence the machine will be brought to a controlled stop with little or no bouncing.

THE EMERGENCY STOP FUNCTION OF THE PANEL WILL CUT THE POWER TO THE PANEL IMMEDIATELY; HENCE THE REVERSE PHASE BRAKING WILL NOT OPERATE.

VIBRATOR RUNNING INTERLOCK

Whilst all "INVICTA" Series 7500 Vibrator Starters are fitted with separate overload relays for each vibrator to give protection against vibrator overload and single phasing (loss of any one of the 3 Phase supply lines), the standard starter cannot detect the complete loss of voltage to a vibrator due to incorrect installation, severed cable etc.

This is particularly important when the starter is used in conjunction with twin "INVICTA" Vibrators fitted, where the loss of the supply voltage is one vibrator will result in the generation of a resultant centrifugal force in a circular mode, rather than the linear mode generated by two contra rotating vibrators. This circular mode may cause excessive movement of the feeder, screen, etc., in a horizontal direction with

resultant mechanical damage. The "INVICTA" type 7508 Twin Vibrator Starters have an additional safety circuit to that:-

- a) If one Vibrator only is connected in circuit when the "Start" button is pressed the "Start" button will be released.
- b) If during the normal running of both vibrators the supply cable to one vibrator is accidentally disconnected or severed, the power to both vibrators is immediately disconnected.

THERMISTOR RELAYS

Each Invicta vibrator is fitted with three PTC thermistors (one for each phase), these are connected in series so that only two terminals exist in the vibrator terminal box, these thermistors must be connected for ATEX applications and should be considered for normal applications as they add an additional safe guard for the motors.

REMOTE STOP (PRESSURE SWITCH)

The Invicta range of control panel, includes a remote connection of a pressure switch this can be used in conjunction with a Mogensen mesh cleaning panel, or other device i.e. Used in ATEX applications for monitoring the forced air ventilation for the enclosed motors or the extraction for the enclosed atmosphere.

ENCLOSURES

The enclosures used are manufactured from 1.5mm steel, finished externally and internally with beige textured epoxy powder paint. The hinged door to the panel is sealed with neoprene gaskets and comes complete with earth terminal, door interlocked isolator, locking handle and cylinder lock.

The enclosure provides a degree of protection against the ingress of dust and liquids to IP 55 (RS 5490 1977, IEC 529 1976).

These units typically use 110V control circuits derived from an internally mounted isolator transformer, other voltages can be supplied.

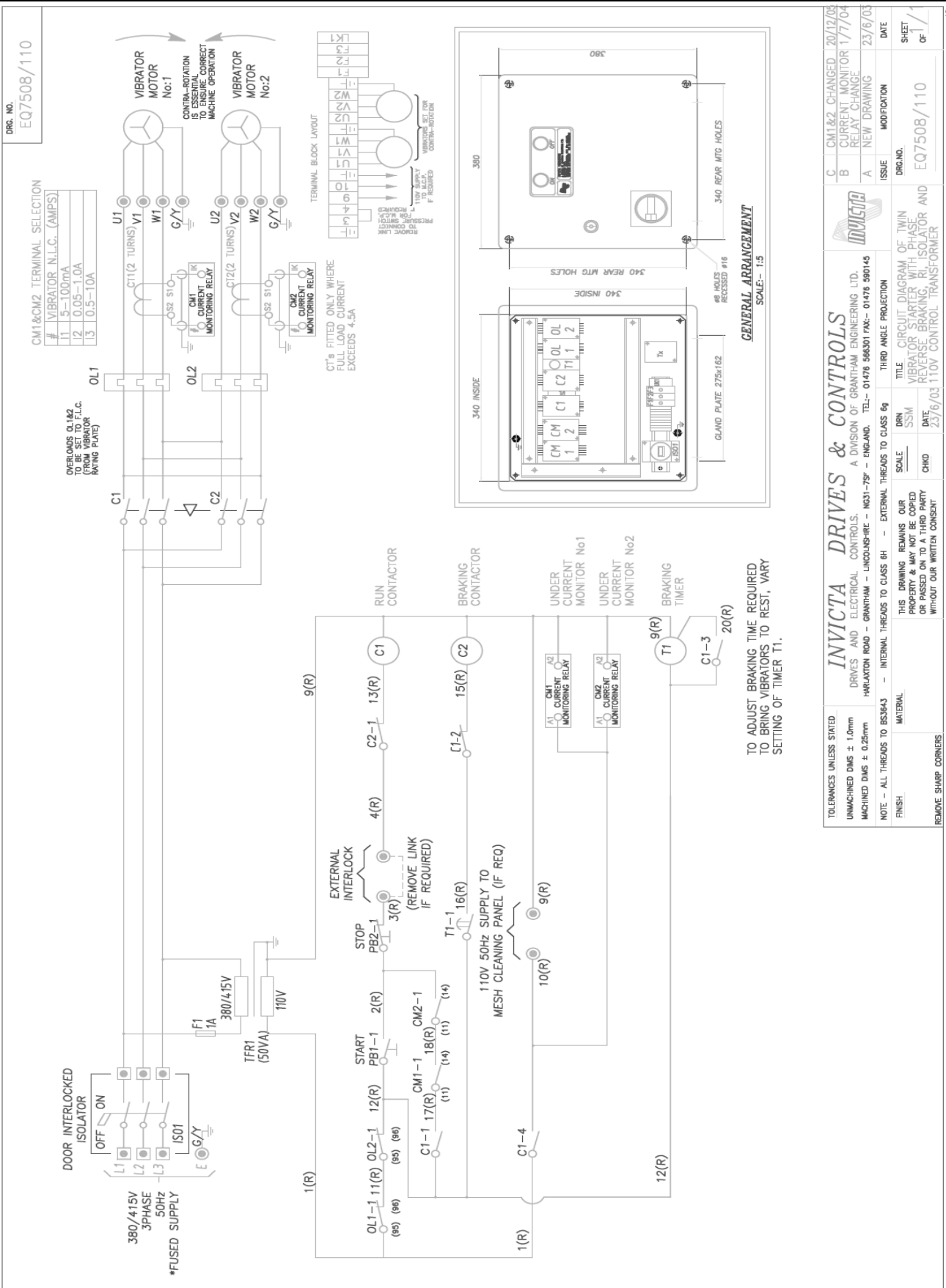

TOLEANCES UNLESS STATED: UNMACHINED DIMS ± 1.0mm MACHINED DIMS ± 0.25mm	FINISH MATERIAL	THIS DRAWING REMAINS OUR PROPERTY & IS NOT TO BE COPIED OR REPRODUCED IN ANY MANNER WITHOUT OUR WRITTEN CONSENT	DRN SSM DATE	SCALE CHD	TITLE VIBRATE BRAKING WITH HATCH AND REVERSE BRAKING WITH MOTOR AND CONTROL TRANSFORMER	DRG. NO. EQ7508/110	ISSUE MODIFICATION	DATE 23/6/03	SHEET OF 1
INVICTA DRIVES & CONTROLS A DIVISION OF GRANTHAM ENGINEERING LTD. HARLTON ROAD - GRANTHAM - LINCOLNSHIRE - NG31-7SF - ENGLAND. TEL:- 01476 566301 FAX:- 01476 590145					THIRD ANGLE PROJECTION				
CM1&CM2 CHANGED 20/12/05									
B CURRENT MONITOR 1/7/04									
A NEW DRAWING									

MAINTENANCE CONSIDERATIONS

Mogensen vibratory equipment once correctly installed will run for long periods with the minimum of maintenance.

An occasional check on the tightness of all the bolts and nuts and the condition of the coil springs is all that should be required.

The machine should **not** be used if:

- Any of the springs are broken.
- Any of the spring retaining straps are detached or broken.
- The rubber spring guards are ruptured or worn away.
- In the case of a side tensioned screen, the machine should not be operated if the mesh deck is loose.
- In the case of a screen fitted with polyurethane decks, the machine should not be operated if the locking wedges or side angles are loose.
- In the case of a lined feeder, the machine should not be operated if the liners are loose.

For details of the maintenance requirements for the Invicta Vibrator Motors, please consult the attached 'Installation and Maintenance guide'.

In the event of spare parts being necessary, please quote the part required and the serial number or contract number of the item of equipment.

PROCESS GUIDELINES

All machines are supplied, unless fitted with a variable speed controller, for operation at a fixed frequency, which dictates the rotation speed of the vibrator. The selection of frequency is determined for each application prior to the supply.

The only variations which should be found necessary are:-

1. Variation of amplitude.
2. Variation of screen deck aperture (screens only).
3. Variation of trough / screen angle (consult Mogensen before making changes)

THE VARIATION OF FREQUENCY WHEN USING A VARIABLE SPEED CONTROLLER WILL NOT AFFECT THE AMPLITUDE.

VARIATION OF AMPLITUDE

The procedure for varying the output of the vibrators is covered within the vibrator manual. The amplitude of the machine should not be greater than is needed. Amplitude of vibratory screens should be set at a point just above where pegging occurs.

VARIATION OF SCREEN DECK APERTURE

Variations to the resultant screened product will be achieved by changing the aperture of the screen panels. A coarser/finer product is obtained by the selection of an aperture above or below the size fitted. Mogensen can advise on the range of apertures normally available. The different methods for securing the screen panels are shown within this manual.

VARIATION OF ANGLE

The procedure for varying the angle of the unit depends on the equipment design, this can either be by raising the rear or front of the unit, or if fitted with angle adjusting frame, by loosening the clamp bolts and raising the rear of the unit.

Unless the equipment is supplied with the provision for angle adjustment, Mogensen should be consulted prior to work being carried out.

GENERAL ADJUSTMENTS

ADJUSTMENT OF AMPLITUDE

In general the amplitude of the machine need never be altered except on such occasions as the fitting of a new vibrator or in the case of a vibratory screen, when a change to the screening process is found necessary. To adjust the machine amplitude consult the 'INVICTA installation and maintenance manual'.

INTERPRETATION OF MOGENSEN STROKEMETER (TWIN VIBRATORS)

On the side of each machine is a small adhesive diagram as shown below. When the machine is started, the base line (line A) will appear to move to a position represented by "line B". The area between "A" and "B" will be blurred. The point where "line B" crosses the angled line (numbered 1 to 10) which will also be blurred represents the amplitude of vibration of the machine in mm. This setting is an important feature of the machine's efficiency and should not be altered unnecessarily.

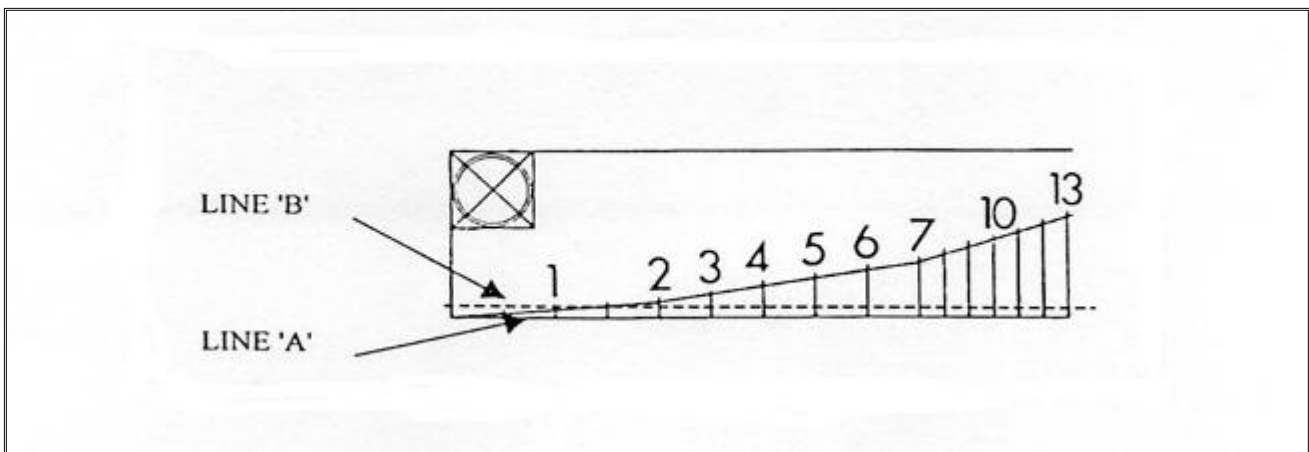

INTERPRETATION OF MOGENSEN STROKEMETER (SINGLE VIBRATORS)

On single vibrator machines the alternative circular stroke-meter shown below is used. To read the stroke of the machine simply identify the circle that appears to describe a circle around a point on its own circumference as shown below.

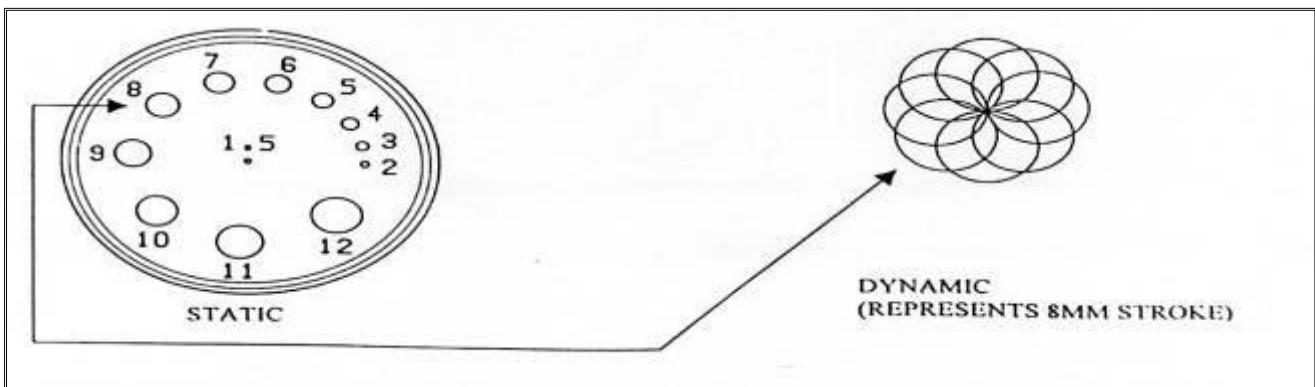

VIBRATOR ATTACHMENT

The vibrators are bolted to the frame and tightened in accordance with the vibrator installation manual. When refitting a vibrator always replace all the vibrator bolts with new ones and re-tighten to the correct setting. Routine changing of all bearings and greasing can be accomplished without removing the vibrators from the frame. Any unnecessary removal of the vibrators is not recommended; in the rare instance of a fastener coming loose, we recommend that both the bolt and lock nut are replaced.

Bolt Size	Torque Value (Nm)
M6	11
M8	28
M10	56
M12	96
M16	242
M20	473
M24	818

GENERAL PLANT FIXINGS

All bolts, studding etc. used on the plant are to Grade 8 - 8 steel and all are tightened to specific torque settings; in the rare instance of a fastener coming loose, we recommend that both the bolt and lock nut are replaced.

The table below shows the full range of torque recommendations. All bolts etc must be tightened according to these recommendations.

TIGHTENING TORQUE FOR METRIC BOLTS

Major Diameter	Grade 8.8			Major Diameter	Grade 8.8		
	Nm	kgf.m	lb.ft.		Nm	kgf.m	lb.ft.
3 mm	0.88	0.09	0.65	12 mm	73	7.44	53.8
4 mm	2.49	0.25	1.84	16 mm	182	18.6	134
5 mm	5.06	0.52	3.73	20 mm	355	36.2	262
6 mm	8.62	0.88	6.36	24 mm	616	62.8	454
8 mm	21	2.14	15.5	30 mm	1228	125	906
10 mm	41.3	4.26	30.8	36 mm	2150	219	1586

Proof stress for 8.8 grade = 571 N/mm²

HANDLING

Care must be taken when handling the machine to ensure that the vibrators are not damaged. This is particularly important if the vibrators are slung underneath. Under no circumstances should the machine be stored on the ground resting on its vibrators.

MESH TENSIONING

As the range of Mogensen equipment is quite varied, there are several methods used for securing and tensioning the meshes within equipment.

SIDE TENSIONED SCREEN DECKS

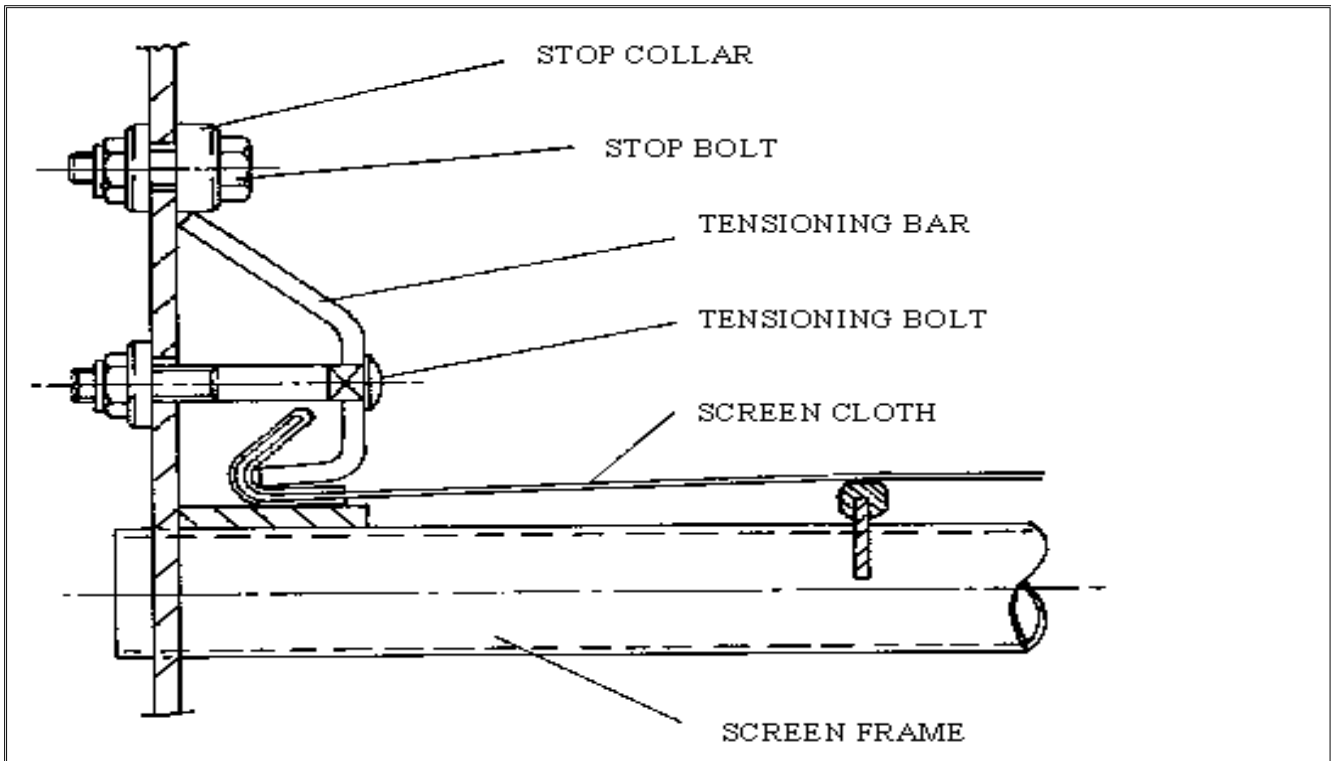

Replacement Procedure:-

1. Remove the tensioning bars and bolts.
2. Remove the old screen cloth
3. Position the new cloth centrally in the width of the screen frame.
4. Replace the tensioning bars and partially re-tighten the tensioning bolts.
5. Ensure the screen cloth is central and fully tighten the tensioning bolts evenly each side of the screen until the screen cloth is drum tight.

1. DO NOT OVER-TIGHTEN OR THE SCREEN CLOTH MAY BE DAMAGED, ESPECIALLY WITH FINE MESH SCREEN CLOTHS.

2. NEWLY FITTED SCREEN MESHES MAY STRETCH DURING THE FIRST FEW HOURS OF USE AND CONSEQUENTLY SHOULD BE CHECKED AT REGULAR INTERVALS.

For screens fitted with centre hold down strips refer to 'Bolted Screen Decks'.

To fit a screen of a different size, it may be necessary to adjust the position of the stop collars as follows:-

1. Slacken off the tensioning bolts and withdraw the old screen.
2. Slacken the bolts and insert the new screen.
3. Slightly tighten the tensioning bolts and the stop bolts
4. With a soft hammer, knock the stop collars down onto the tensioning bar until the screen cloth hook-strip sits firmly on the screen frame.
5. Tighten the stop bolts and then re-tighten the tensioning bolts as above.

END TENSIONED SCREEN DECKS

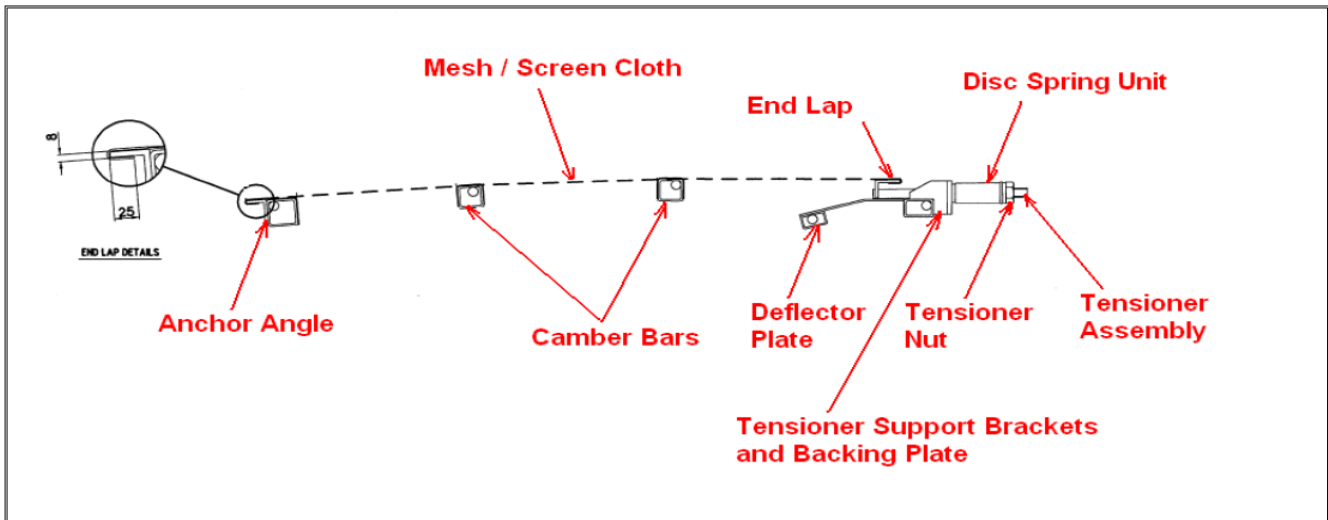

The screen meshes are hooked on to the anchor angle, then pulled tight by the tensioner assembly fitted at the rear of the screen, the number of tensioner nuts depend on the width of the mesh panel, which will either have 1, 2 or 3 nuts.

These bolts should always be pulled tight and fitted with the correct colour coded disc spring unit as detailed in the following diagram.

Spring Washer Capsule

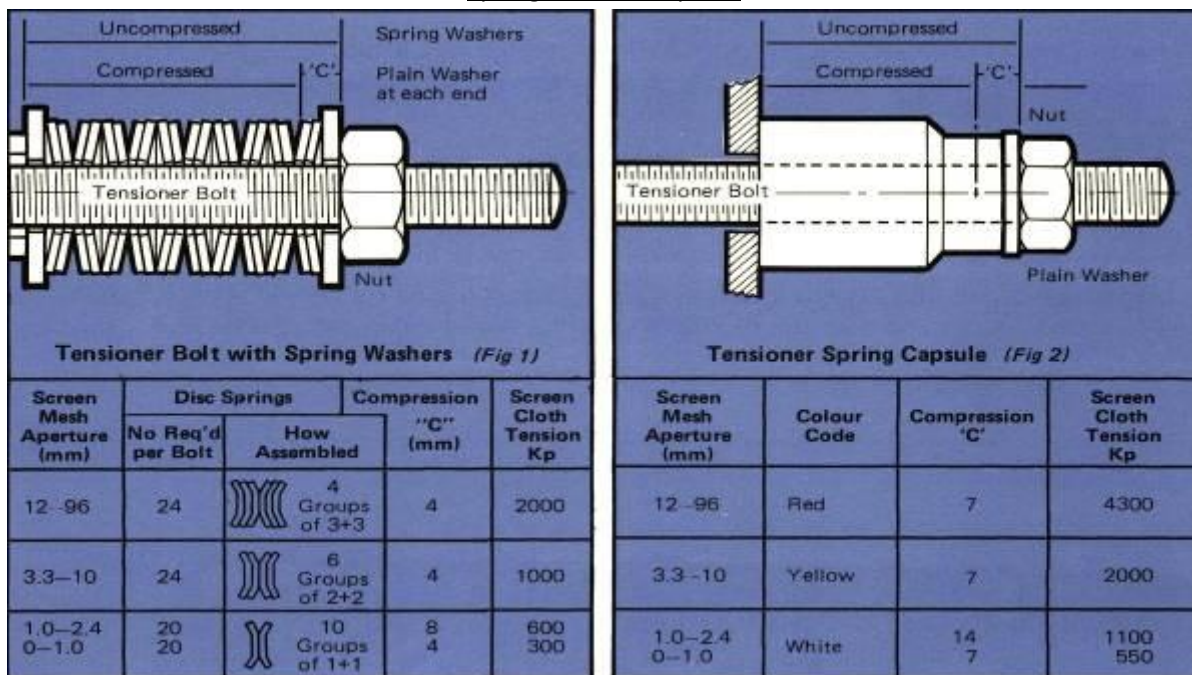

Screen meshes which have not been tightened sufficiently, will rattle when the machine is running and if allowed to continue, will fail prematurely, a typical indication of insufficiently tensioned mesh is mesh failure along the edges of the camber bars as this is where the mesh will flex.

Newly fitted screen meshes stretch during the first few hours of use and consequently should be checked at regular intervals. Mesh tightening can be accomplished without necessarily stopping the machine if it is evident which meshes are loose.

The final test as to whether a mesh is adequately tensioned depends on its quietness. If it rattles, apply a little extra tension.

Replacement Procedure:-

1. Loosen the tensioning nut(s) and push the stud(s) to loosen and unhook the mesh from the tensioner.
2. Unhook the lower end of the meshes from the anchor angle.
3. The mesh may then be either withdrawn from the tensioner end or anchor angle end of the machine.
4. Prior to refitting mesh, ensure that the tensioners, camber bars and anchor angles are clean, so that the mesh seat correctly.
5. Replace the screen mesh by reversing the above procedure, ensuring the correct 'disc spring units' are used for the mesh apertures.
6. When tightening the meshes, tighten the tensioners evenly so as to reduce point loading. on the mesh, initially tension the mesh so that they feel tight to the touch over the whole width, then apply additional tension until the screen is drum tight this can normally be tested by tapping the mesh surface with blunt object (such as a spanner).
7. Once tensioned the screen should be ran, and if the meshes appear to rattle apply a little more tension until the rattle ceases, it should also be noted that meshes will stretch with use so should be periodically re-tensioned.

NOTE

DUE TO THE POTENTIAL WEIGHT OF THE SCREEN DECK AND COMPONENTS, USERS MUST MAKE THEIR OWN ASSESSMENTS OF THE RISKS AND PROVIDE THE APPROPRIATE PROVISIONS FOR HANDLING.

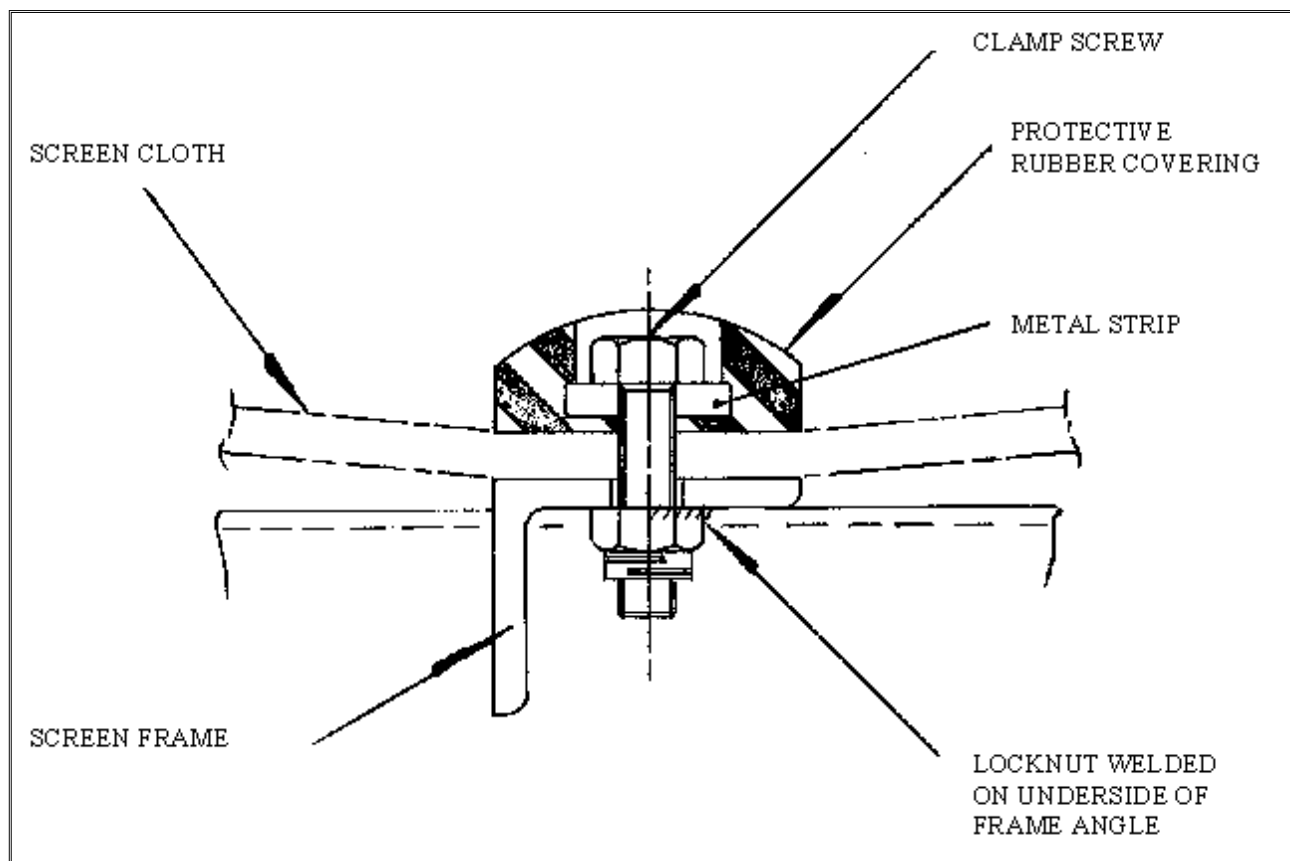
BOLTED SCREEN DECKS - DESIGN 1

On wide screens this centre hold down strip is used to prevent the screen cloth rising under vibration and to reduce the angle of camber at the outer edges of the screen cloths.

To replace a screen cloth, remove all the clamp screws and remove the rubber covered strip, then remove and replace the screen as detailed in the 'side tensioned screen decks'. Place the new cloth in position centrally in the width of the screen and mark wires which obscure the bolting down holes. Remove the wires where marked and re-position the cloth.

Re-fit the centre holding down strip and slightly tighten the clamp screws. Ensure that the screen cloth is central in the frame and fit the outer tensioning bars back in position with the tensioning bolts partially tightened. Fully tighten the clamp screws in the centre hold down strip and then fully tighten the tensioning bolts until the screen cloth is drum tight.

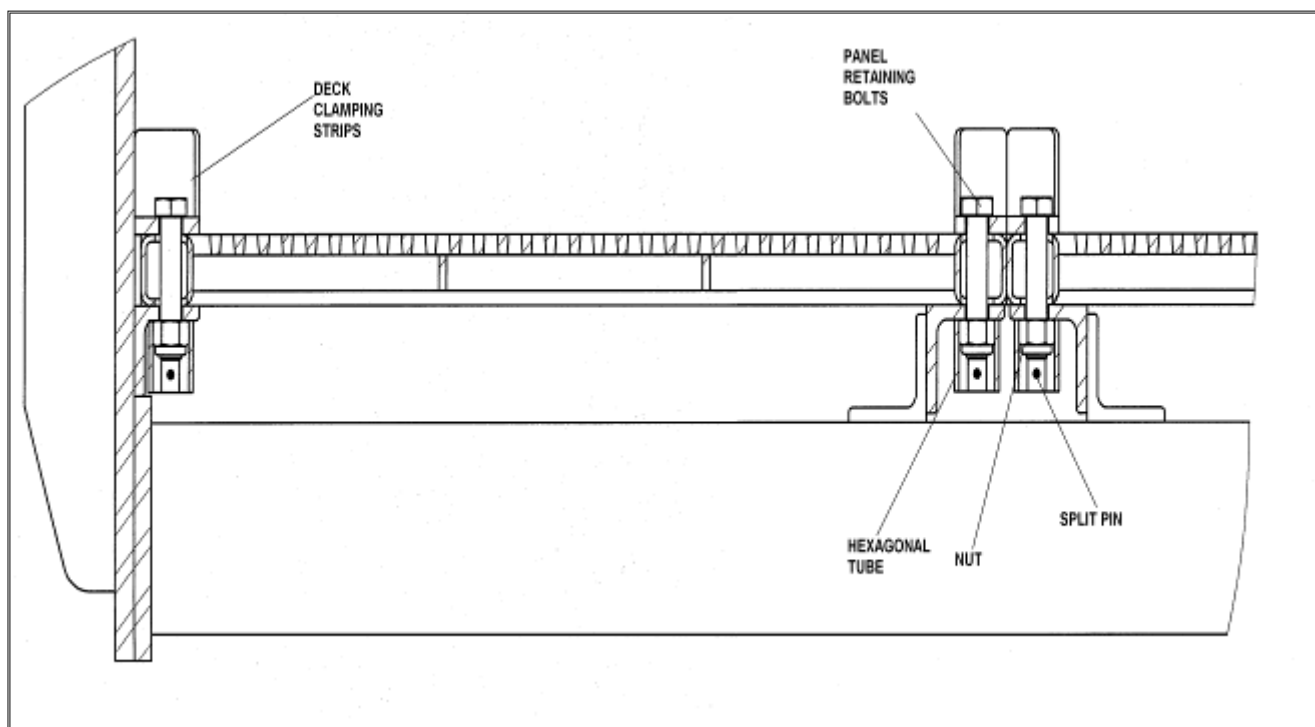
BOLTED SCREEN DECKS - DESIGN 2

To remove the screen decks it should only be necessary to remove the panel retaining bolts and deck clamping strips. The nuts underneath the decks are retained and prevented from rotating by a hexagonal tube and split pin arrangement therefore removal of the bolts should only require access to the top of the deck. If the nuts become damaged and need to be replaced they must be extracted from below once the split pin has been removed. When re-fitting the decks, please ensure the deck clamping strips are installed with the deflectors protecting the bolt heads from the flow of material.

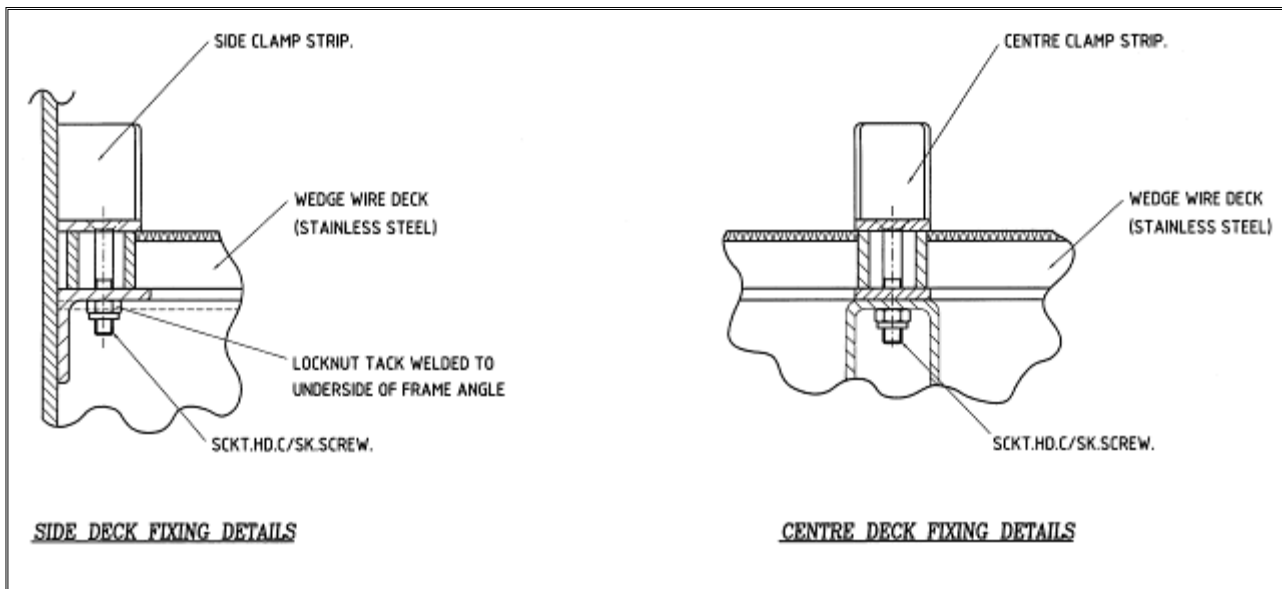
BOLTED SCREEN DECKS - DESIGN 3 (WEDGE WIRE)

To remove the screen decks it should only be necessary to remove the panel retaining bolts and deck clamping strips. The nuts underneath the decks are retained and prevented from rotating by tack welding them to the structure; therefore, removal of the bolts should only require access to the top of the deck. If the nuts become damaged and need to be replaced they must be extracted from below. When re-fitting the decks, please ensure the deck clamping strips are installed with the deflectors protecting the bolt heads from the flow of material.

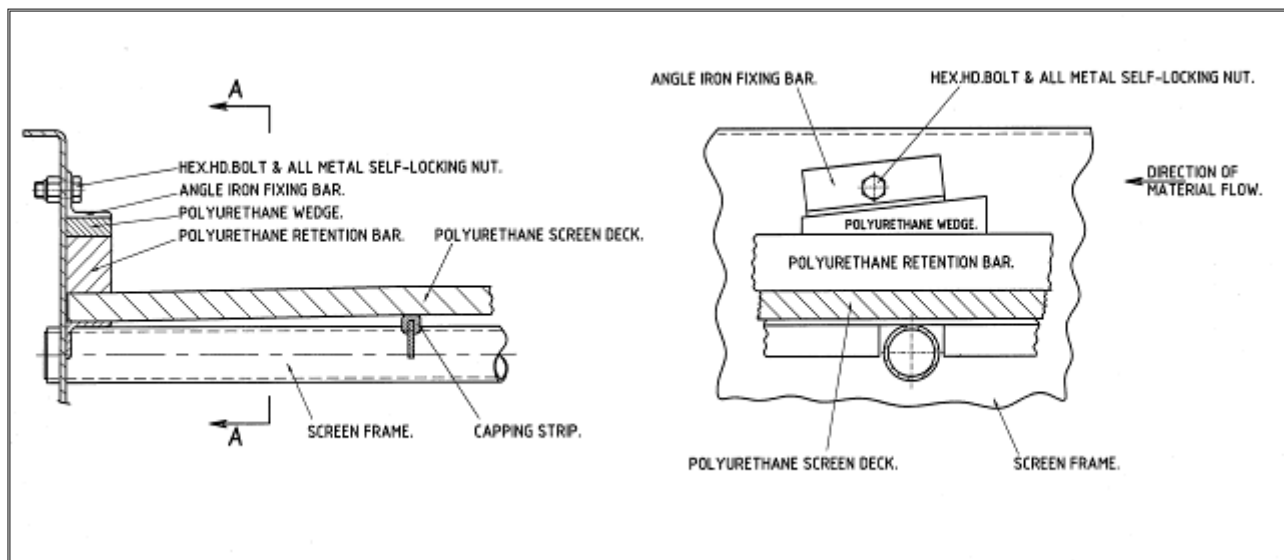
POLYURETHANE SCREEN DECKS

The polyurethane decks are held in position by a system of wedges as shown in the diagram above. Please observe the direction of fitting of the tapered wedge is with the direction of material flow. This is to ensure the wedges are not vibrated loose by the conveying action of the machine.

When fitting the deck assembly, ensure the screen deck supports are clean and flat. If multiple panels are used, ensure there are no gaps between the panels as they are fitted. The bolt holding the iron angle fixing bar should be left loose until the wedge has been fitted and correctly tightened. The retention bar and wedge should be pushed up against the side of the machine which should be clean and free from debris. When fitting a deck assembly for the first time, ensure the angle iron fixing bar is free to rotate on the bolt. Drive the wedge home under the angle bar with a rubber mallet ensuring the wedge stays flat up against the side of the machine as it tightens. Once the screen is locked in place tighten the nut and bolt to the torque specified in the table headed 'General Plant Fixings' within the section of 'General Adjustments'. Ensure all wedges are correctly positioned before the machine is operated.

If screen deck panels need to be removed and refitted, as long as the same components are reused, it should not be necessary to change the position of the angle iron fixing bar. The removal procedure simply consists of driving the wedges out from under the angle iron fixing bar, which allows the other screen components to be removed by hand.

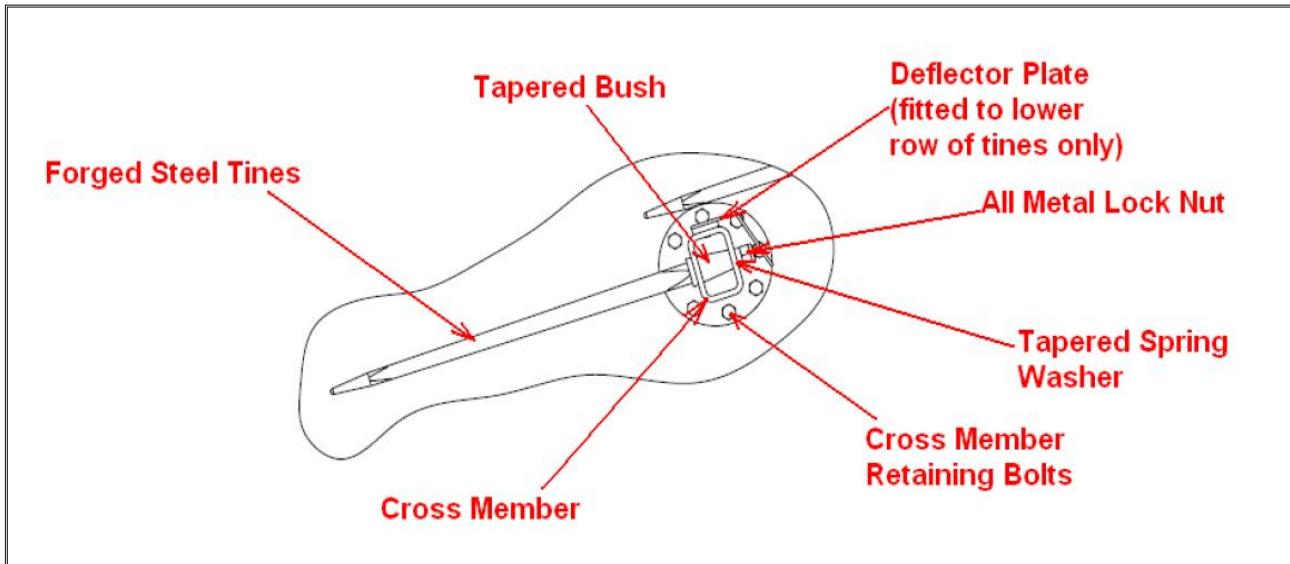
FORGED STEEL TINE DECKS

The deck design consists of four main items, the forged steel tine, a tapered bush, a tapered spring washer and a locking nut.

The forged steel tine is square in section, so can be used on diamond or on square with a flat surface on the top, it has a gradual taper along the length of the product end, and a short taper and thread at the locking end, which locates within the tapered bush..

The front of the bush has a taper which matches that of the tine, on the rear of the bush is a small tapered recess which matches the angle of the spring washer; these bushes are welded into a cross member which passes across the screen being either welded in position of as bolt-in versions where interchangeability may be required.

Tine Fitting Procedure:-

1. Clean the tapered bush and tine taper.
2. Place the tine in to the tapered bush, rotating the tine to the required cross section (diamond or square), before pushing firmly into the taper.
3. Fit the tapered spring washer on the rear and secure in place using the locknut.
4. To fully secure the tine it is necessary to hammer the end of the tine to bed it into the bush, this should be done whilst tightening the retaining locknut.
5. The thread on the tines is a M20 metric fine thread, as such should be torqued as 528NM.
6. When hammering the tine creates no slack for the nut and the nut is at the correct torque, the tine should be correctly seated.

Tine Removal Procedure:-

1. To remove the tines, loosen the locknut so that it protects the end of the thread.
2. Gently tap the nut with a hammer, to dislodge the tine from the taper.

3. Whilst supporting the tine, remove the locknut and washer and withdraw the tine from the

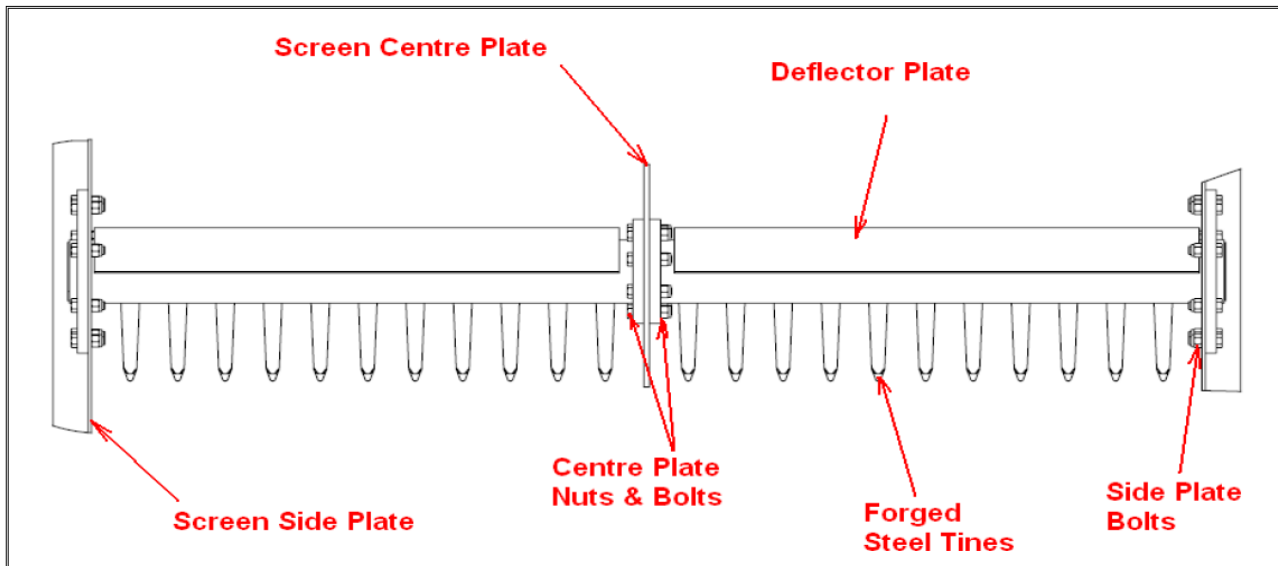

bush.

When tines are fitted in conjunction with bolt-in cross members, the procedure for removing these is as follows:-

1. Remove the tines as detailed on the previous page.
2. By accessing the machine from the front, rear and back, remove all but one retaining bolt from both the centre and side plates.
3. Upon removing the remaining bolts, the cross member can be removed through the side of the screen.
4. Refit by reversing the above procedure.

NOTE

DUE TO THE POTENTIAL WEIGHT OF THE SCREEN DECK AND COMPONENTS, USERS MUST MAKE THEIR OWN ASSESSMENTS OF THE RISKS AND PROVIDE THE APPROPRIATE PROVISIONS FOR HANDLING.

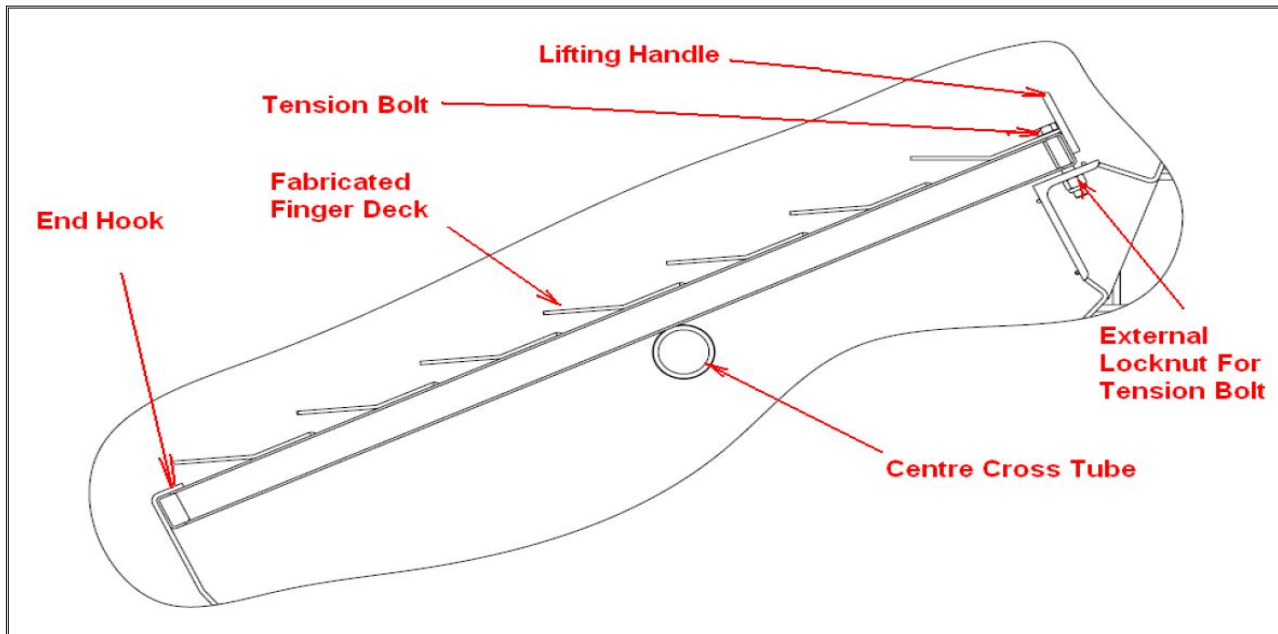
FABRICATED STEEL FINGER DECKS

The fabricated deck, can be loaded from the rear or front of the machine, with lower end locating under a hook, with the centre being supported over a cross tube, the deck is then secured at the rear of the machine, with a bolt which is bolted through the mainframe tensioning the deck over the cross tube.

Fitting Procedure:-

1. Open up the rear and front of the unit to gain access.
2. Ensure the underside of the end hook, cross member and top fixing points are clean so that the deck can be seated correctly.
3. Slide the deck in from either the rear or front of the unit, ensuring the deck is in the correct orientation.
4. Fit the tension bolt and locknut, tightening to tension the deck over the cross member.
5. If additional tension is required, a shim can be placed at the lower end of the deck, between the deck and end hook.

Removal Procedure:-

1. Reverse the above procedure.

NOTE

DUE TO THE POTENTIAL WEIGHT OF THE SCREEN DECK AND COMPONENTS, USERS MUST MAKE THEIR OWN ASSESSMENTS OF THE RISKS AND PROVIDE THE APPROPRIATE PROVISIONS FOR HANDLING.

ISOLATION MOUNTINGS

The following diagrams show examples of the types of isolation mount used on Mogensen equipment; if inclining or declining the plant, slacken the clamp bolt or pivot bolt (as appropriate) and set the spring unit to the required angle and re-tighten, ensuring that the springs are vertical.

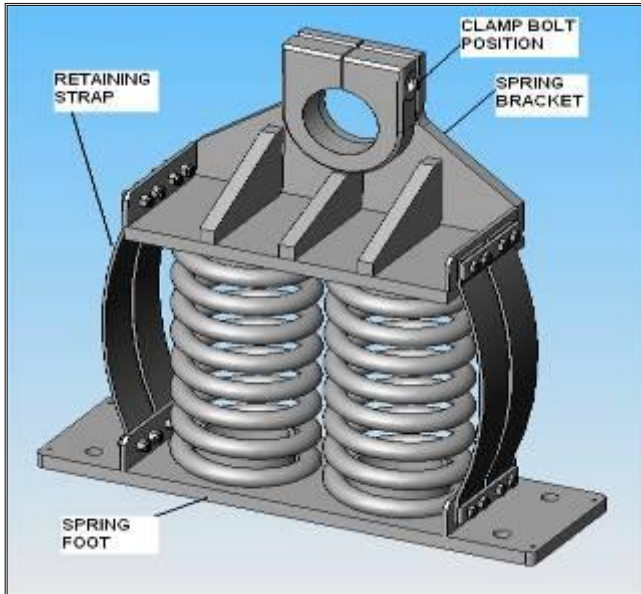

TYPE - 1

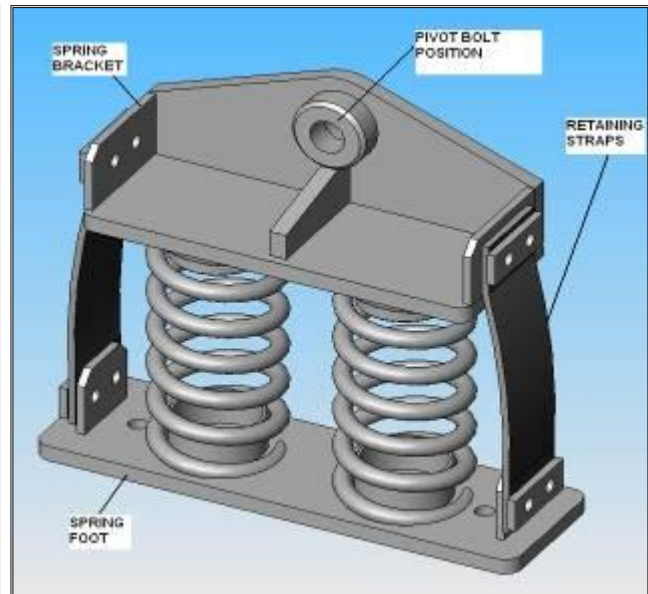

TYPE - 2

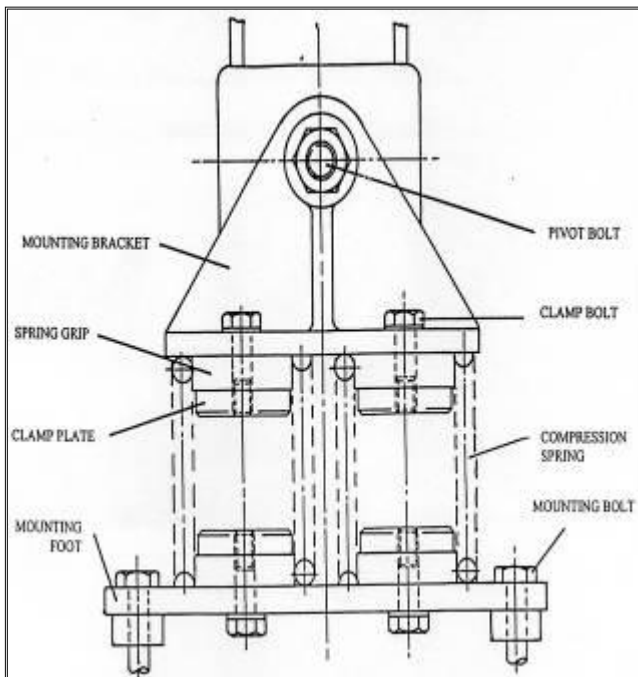

TYPE - 3

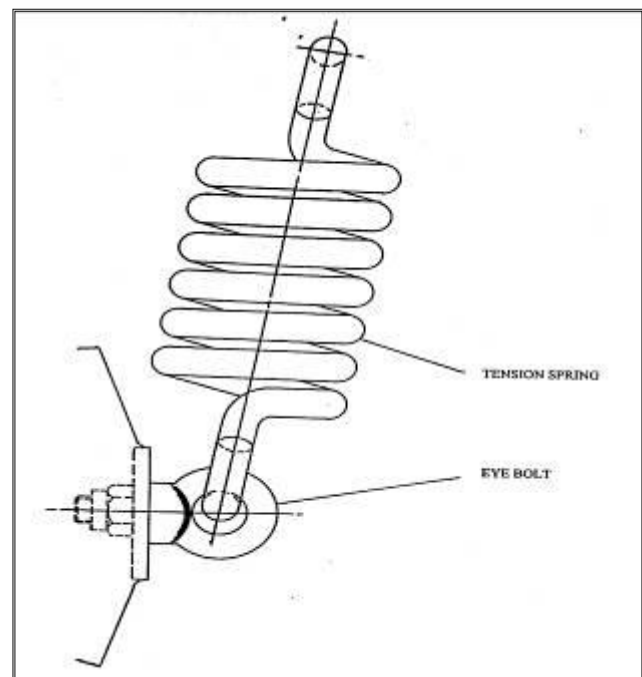

TYPE - 4

Springs may be mounted to static top mounting brackets integral to the fabrication of the machine body or via adjustable mounting brackets as shown in the above diagrams, with some applications the equipment may be mounted on suspension springs.

SPRING REPLACEMENT (TYPE – 1 & TYPE – 2)

1. Support the plant to relieve any spring loading.
2. Loosen the clamp bolt or remove the pivot bolt.
3. Remove the retaining straps.
4. Lift the spring bracket off the springs.
5. Remove the spring and rubber cover (not shown).
6. Fit the rubber cover over the new spring.
7. Fit the new spring, ensuring that the replacement spring is correctly located on the metal spigot.
8. Re-assemble the other components and making sure that the springs are not mis-aligned.
9. Re-fit and tighten the clamp bolt, or tighten the pivot bolt as required and then re-fit the retaining straps.
10. Lower the machine to re-load the springs, ensuring the clearances around the machine are as detailed on the installation drawing.

SPRING REPLACEMENT (TYPE – 3)

1. Support the plant to relieve any spring loading.
2. Loosen the pivot bolt.
3. Loosen the upper and lower clamp bolts to release the compression from the spring grips.
4. Lift the mounting bracket off the springs.
5. Remove the springs and rubber cover (not shown).
6. Fit the rubber cover over the new spring.
7. Fit the new spring, ensuring that the replacement spring is correctly located over the clamp plate and spring grip.
8. Re-assemble the other components and making sure that the springs are not mis-aligned.
9. Re-fit the pivot bolt.
10. Lower the machine to re-load the springs, ensuring the clearances around the machine are as detailed on the installation drawing.
11. Re-tighten the clamp bolts to compress the spring grips.

SPRING REPLACEMENT (TYPE – 4)

1. Support the plant to relieve any spring loading and provide sufficient clearance so the spring can be un-hooked.
2. Replace the spring.
3. Lower the plant to re-tension the spring, ensuring the clearances around the machine are as detailed on the installation drawing.

AFTER REPLACING SPRINGS, THE EQUIPMENT SHOULD BE MONITORED DURING START-UP AND THE TENSION OF ALL BOLTS RE-CHECKED AFTER THE UNIT HAS BEEN OPERATIONAL FOR A COUPLE OF HOURS.

INSTALLATION CHECK LIST**PRIOR TO LIFTING / INSTALLATION**

DESCRIPTION	CHECKED
1. The surface / structure on which equipment is to be installed should be flat and suitably rigid to withstand the static and dynamic loads applied by the equipment and prevent unplanned secondary vibration.	
2. Consideration should be given to the nature of the material being processed in-case this is likely to produce additional noise as it passes through the machine; in some instances this may necessitate the wearing of ear protection in the vicinity of the equipment.	
3. Consideration should be given to providing adequate clear unobstructed access around the equipment for maintenance.	
4. If the equipment is to be enclosed within a structure allowances should be given for any air-movement /pulses created by the equipment as these may create uncomfortable buffeting sounds, or effect flexibly mounted structures which can become loose.	
5. Prior to lifting, study the installation drawing for the lifting guidance and ensure any transport straps fitted between the vibrating unit and static section are secure, or make suitable provisions to secure both items together.	

DURING INSTALLATION

DESCRIPTION	CHECKED
1. Ensure the equipment is installed with the necessary clearances as stated on the installation drawing.	
2. Ensure the sides of the unit are vertical.	
3. Ensure that any transport straps fitted for transportation / lifting of the equipment are removed and that all spring assembly components are refitted .	

BEFORE STARTING

DESCRIPTION	CHECKED
1. Check that springs are intact, correctly seated and that the spring brackets are horizontal.	
2. Check that spring covers are correctly seated and undamaged.	
3. Check that the holding down bolts on the supporting framework are tight.	
4. Check that the screen meshes are tight (Vibratory Screens only).	
5. All covers and their fastenings, must be inspected prior to operating the equipment to check they are secure; quick release fasteners may be used to speed up the removal, but these must be used in conjunction with bolted fixings	
6. Check that the sides of the machine are vertical.	
7. Check that the machine can vibrate freely without touching surrounding structures or equipment.	
8. Check that electrical supply is correct and that the internal connections of the vibrator terminal boxes are correct.	
9. Check that all out-of-balance weight settings are exactly equal and that the pairs of weights in each vibrator are exactly lined up.	

10. Check the vibrator overload settings and adjust cut-out if necessary.	
11. Check that electrical cables are properly supported and not rubbing against anything.	
12. Any cables replaced should be of identical length to those provided on original equipment.	

INITIAL START-UP (Without feed to the machine)

DESCRIPTION	CHECKED
1. Check vibration to see that it is linear (twin vibrators only) in the correct direction and of the correct amplitude.	
2. Check for quiet running. The machine should not make any clattering noise (Refer to plant noise level certificate for noise levels recorded during the initial test).	
3. Check that the two vibrators are counter rotating. (Twin vibrators only) on single vibrator machines set the rotation with the flow of the material.	
4. Check the reverse phase breaking is operating correctly.	
5. Set up the current monitoring relays.	

INITIAL START-UP (With feed to the machine)

DESCRIPTION	CHECKED
1. Check the feed is flowing steadily onto the feed plate of the unit at a constant rate, ensuring the velocity does not exceed 400mm/sec.	
2. Check the feed is spread evenly across the whole width of the inlet.	
3. Check the unit is free moving with a full load and that it is clear from static objects.	

EQUIPMENT HANDLING, DE-COMMISSIONING, DISMANTLING AND DISPOSAL

HANDLING / LIFTING

When installing or removing Mogensen equipment only the authorised lifting points should be used as shown on the equipment installation drawing; these lifting points are 100% load tested at the factory complete with all attached items shown on the installation drawing.

When lifting this equipment care should be taken to ensure all items are securely attached to the vibratory equipment being raised and in instances where support frames are supplied with the equipment this support frame must be strapped securely to the main body throughout the period of the lift.

The interconnecting spring assemblies are not designed to support the support stand weight.

All lifting must be carried out in accordance to the latest regulations, by suitably trained and qualified personnel, who should use shackles, chains and slings as required.

DECOMMISSIONING AND DISMANTLING

The decommissioning and dismantling of the equipment should be carried out by trained and qualified personnel, and must be carried out in accordance with the required health and safety legislation.

Prior to dismantling the equipment, all services should be isolated, lock off and disconnected and clarification should be sought as to the materials previously being processed by the equipment in case these were hazardous to health.

DISPOSAL

Most components used in the manufacture of the Mogensen equipment are suitable for recycling, however if there is any doubt with regard to the materials of construction, then clarification should be sought from Mogensen.

All equipment should be disposed of in a safe and responsible manner, as required to comply with regional and national legislation.

FAULT FINDING GUIDE

SYMPTOM	POSSIBLE FAULT
Vibrator too hot (i.e. hotter than 70°C)	<ul style="list-style-type: none"> a) Bearing worn b) Vibrators "Single-phasing" c) Vibrators not tightly bolted down d) Only 1 vibrator of pair receiving current.
Vibrator or vibrators drawing excessive current	<ul style="list-style-type: none"> a) Bearing worn b) Vibrators "Single-phasing" c) Vibrators not tightly bolted down d) Only 1 vibrator of pair receiving current. e) Attachments such as chutes working loose where fitted f) Frame cracked
Loud rattling noise	<ul style="list-style-type: none"> a) Bearing worn b) Meshes loose or broken (Screens only) c) Support structure not stiff enough d) Chutes or covers loose where fitted e) Machine or springs touching fixing structure.
Loud, heavy buzzing noise	<ul style="list-style-type: none"> a) Vibrator inadequately tightened down b) Frame cracked.
Both vibrators running but very little vibration.	<ul style="list-style-type: none"> a) Vibrators running in same direction instead of counter rotating b) Eccentric weights missing from vibrator. c) Weight setting incorrect.
Smaller vibration than expected but vibration linear (twin vibrators)	<ul style="list-style-type: none"> a) Out of balance weights need adjusting
Vibration less than expected; vibration elliptical or circular (twin vibrator machine)	<ul style="list-style-type: none"> a) Only one vibrator running
Machine vibrating sideways, erratic	<ul style="list-style-type: none"> a) Vibrator weights not in line and not set equally or in some models vibrators not counter-rotating.
Excessive carry over of fines into	<ul style="list-style-type: none"> a) Machine overloaded
Machine bouncing excessively (secondary oscillation);	<ul style="list-style-type: none"> a) Support framework not stiff enough b) Machine sides not vertical
Premature Mesh panel Failure	<ul style="list-style-type: none"> a) Meshes incorrectly fitted b) Meshes loose c) Machine as a whole or one or two particular meshes overloaded (wrong mesh combination?) d) Damp material clinging to meshes (electric deck-heating or mesh rapping needed).
Material spills out over the tensioners (single vibrator screens only)	<ul style="list-style-type: none"> a) Vibrator running in the wrong direction. b) Change direction of rotation