

ACE100 - 100mm (4") Automatic Priming Pump

SPP Pump's AUTOPRIME ACE100 pump is a compact diesel driven pump unit designed for ease of handling and ability to pump most liquids including sewage and small semi solids. Typical uses are removal of ground and rain water from excavations, trenches, footings, manholes and ponds etc. May also be used for stream and pipe diversions and flood water control.



DESIGN FEATURES

- Road trailer with ball or ring hitch, and central lifting point. Optional skid or un-mounted versions.
- Fully enclosed 12volt battery for safety and security with starting by key switch.
- Pump will pass solids up to 1.6" (40mm) diameter.
- Reliable double mechanical seals, which allow dry running for extended periods.
- Pump will prime itself automatically when liquid is present and can be left running unattended.
- Rugged construction requires minimal operator maintenance.
- Dry running 25 cfm (40 m3/h) Vacuum Pump exhausts oil free air direct to atmosphere.
- Pump will run on load for 24 hours before refuelling.

PUMP SPECIFICATIONS

Flow Rate	136m3/h Maximum
Discharge Head	25m Maximum
Suction Hose Size	100mm (4") Diameter
Discharge Hose Size	100mm (4") Diameter
Max Solids Size	40 mm (1.6")Diameter
Pump Casing	Cast Iron
Impeller	SG Cast Iron
Pump Shaft	Stainless Steel
Wear Plates	SG Cast Iron
Suction Sump	Cast Iron

Shaft Seal	Silicon Carbide/Silicon Carbide	
Elastomer	Viton	
Diesel Engine	Hatz 1D90 Air Cooled	
Power Rating	7.7kW @'2000rpm	
Starting	12 Volt Battery by Key Switch	
Fuel Tank Capacity	55 litres	
Full Load Consumption	2.3 litres/hour average	
Full Load Running Time	24 hours	
Chassis Options	Road Trailer or Skid Mounted	
Weight – With Fuel	477 kg)	

Specifications may be subject to change without notice.

ACE100rev03

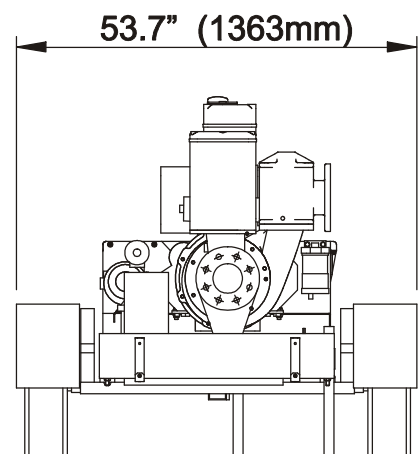
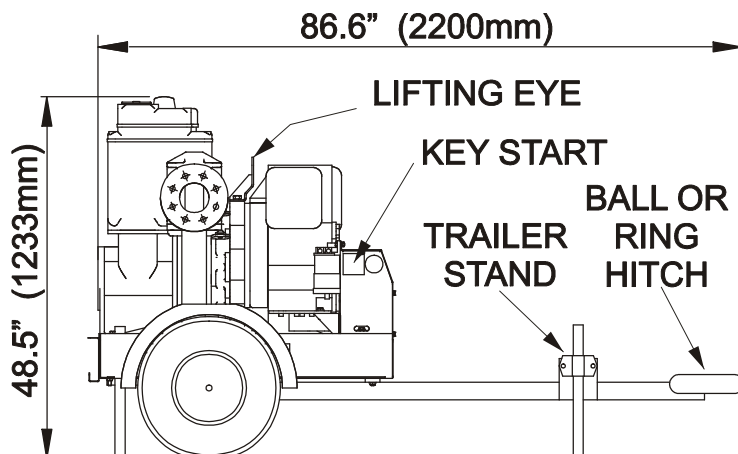



AUTOPRIME

ACE100 x 1D90

Curve Ref: ACE100-1D90-v1

Speed: 2000 rpm Nominal

Suct x Disch: 100 x 100 mm

