

DEWATERING HYDRAFLOW DATA SHEET

S4T 100MM HYDRAULIC SUBMERSIBLE SEWAGE PUMP

The SPP HYDRAFLOW S4T Hydraulic Drive Submersible Pump is our most versatile 100mm pump. It is rugged, compact and able to pass large solids, this pump is designed to tackle many jobs ranging from general construction site dewatering to sewage and slurry pumping.

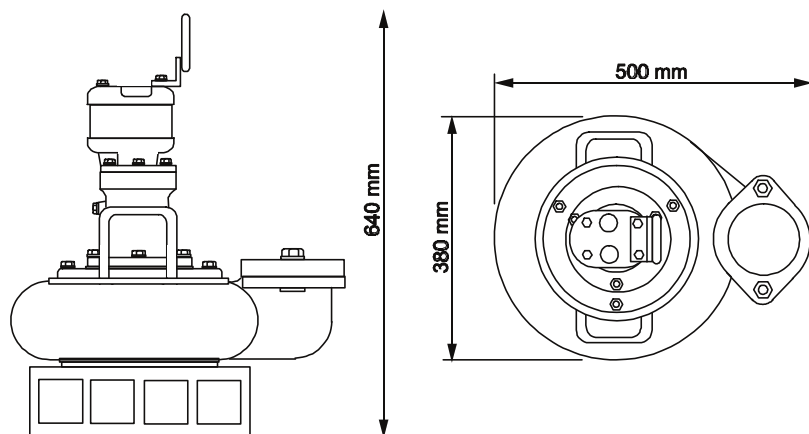

DESIGN FEATURES

- 2-vane Channel Impeller will pass 75mm Semi-Solids.
- Light weight - can be carried by two men, casing also available in Stainless Steel.
- Oil lubricated seals - pump can run dry.
- Variable speed with dependable gear type hydraulic motor.
- Wide range of performance.
- Can be bolted into a pipeline.
- Safe Hydraulic Drive can be used where electric power is hazardous or impractical.
- Operates with our HT60D Hydraulic Power Unit or any open centre power source with output flows to 98 l/m.



DEWATERING

HYDRAFLOW DATA SHEET

PUMP SPECIFICATIONS	
FLOW RATE	197 m ³ /h Maximum
DISCHARGE HEAD	27.5 m Maximum
WEIGHT	74 kg
HEIGHT	640 mm
MAX DIAMETER	500 mm
MAX SOLIDS SIZE	75 mm Diameter
HOSE PORT	1" NPT F
SUCTION FLANGE	n/a
DISCHARGE PORT	4" NPT F
POWER SOURCE	HT25D, HT35D or HSQ35D
PUMP CASING	Ductile Iron/Stainless Steel
IMPELLER	Ductile Iron
WEAR RING &/OR PLATE	Stainless Steel
SHAFT	Carbon Ceramic
SHAFT SEAL - STANDARD	Carbon Ceramic
ALTERNATIVE SEAL	Silicon Carbide
ELASTOMERS - STANDARD	Buna (N)
HYDRAULIC OIL	214-320 s.s.u. @ 64 Deg. C
INPUT FLOW	57l/m Maximum
OPERATING PRESSURE	172 bar Maximum

HYDRAULIC SUBMERSIBLE PUMP

PUMP TYPE	S6T
BRANCH SIZES	Suction: 150mm x Disch: 150mm
IMPELLER	Vortex
SOLIDS HANDLING	125 mm diameter
HYDRAULIC MOTOR	Gear
INPUT - HYDRAULIC FLOW	98l/m
INPUT - HYDRAULIC PRESSURE	207 bar
HYDRAULIC OIL	ISO 46
HYDRAULIC OIL TEMPERATURE	Max 140°F