

HL125M Dri-Prime® Pump

The Godwin Dri-Prime HL125M pump is an extremely powerful yet compact pump with flow capabilities to 299 m³/hr and discharge heads to 134 metres.

The HL125M features the unique Godwin high pressure oil bath mechanical seal design. This allows for dry running for prolonged periods while automatically priming and repriming. Able to perform in the toughest conditions, the HL125M can handle solids up to 35 mm in diameter. This makes it an extremely effective pump, suitable for both slurry and clean water applications. The powerful HL125M has proven itself a pump of choice for sewer bypass, general dewatering and many other applications.



Features and Benefits

- Fully automatic priming from dry to 8.5 metres suction lift.
- Godwin Dri-Prime is a continuously operated Venturi air ejector priming device which requires no periodic adjustment or control.
- Extensive application flexibility. It will handle sewage, slurries and liquids with solids up to 35 mm in diameter.
- Dry-running high pressure oil bath mechanical seal, with high abrasion resistant silicon carbide faces.
- A Close-coupled centrifugal pump with Godwin Dri-Prime system mounted to a diesel engine or electric drive.
- All cast iron construction (stainless steel construction option available) with cast steel impeller.
- Also available as Hush-Pac or as a bareshaft pumpend.
- Standard build engines; Perkins 1106D-E66TA (129), Perkins 1104D-E44TA. Other engine options are available.

Specifications

Suction connection	150 mm (6" BS10 table 'D')
Delivery connection	100 mm (4" BS EN 1092 PN16)
Max capacity	299 m ³ /hr
Max Head	134 metres
Max Solids handling	35 mm
Max Impeller diameter	370 mm
Max operating temp	80 °C
Max working pressure	13.5 bar
Max suction pressure	6.0 bar
Max casing pressure	20.3 bar
Max operating speed	2400 rpm

godwin 
a xylem brand

Performance Curve

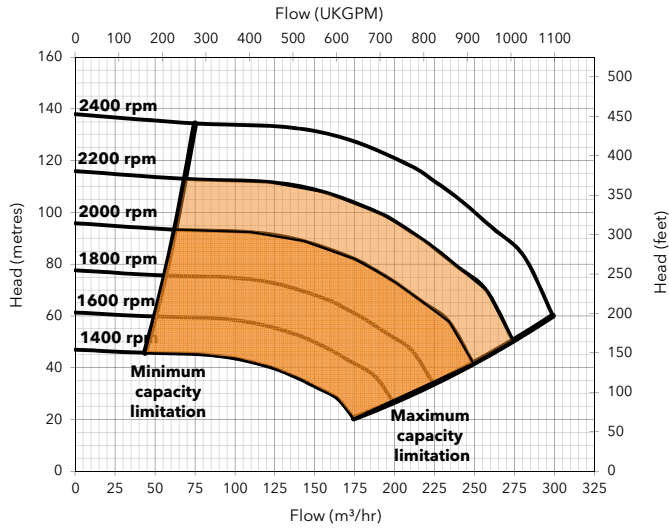

Engine option 1

Price list ref - HL125M-01-DBO-002

Perkins, 1106D-E66TA (129), 103.5 kW @ 2200 rpm

Impeller diameter 370 mm

Pump Speed 2200 rpm

Suction Lift Table

Total Suction Head (metres)	Total Delivery Head (metres)				
	43	61	79	91	103
	Output (m³/hr)				
3.0	275	264	237	204	165
4.6	275	264	231	198	154
6.1	216	198	165	143	121
7.6	158	149	132	110	66

Fuel capacity (Full) 475 litres, (Usable) 388 litres

Fuel consumption @ 2200 rpm BEP 26 litres/hour

Weight: (Dry) 2,200 kg, (Wet) 2,600 kg

Dimensions: (L) 2,950 x (W) 1,300 x (H) 1,900 mm

Performance data provided in tables is based on water tests at sea level and 20°C ambient. All information is approximate and for general guidance only. Please contact the factory or office for further details.

Materials

Pump casing & suction cover	Cast iron BS EN 1561 - 1997
Wearplates	High Chromium Cast Iron HC403:1977 Hardened to 480 HB Brinell
Pump Shaft	Carbon steel BS EN 1561 - 1997
Impeller	Cast Steel BS3100 A5 Hardness to 200 HB Brinell
Non-return Valve body	Cast Iron BS EN 1561 - 1997
Mechanical Seal Faces	Silicon carbide vs silicon carbide

Engine option 2

Price list ref - HL125M-01-DBO-001

Perkins, 1104D-E44TA, 74.1 kW @ 2000 rpm

Impeller diameter 370 mm

Pump Speed 2000 rpm

Suction Lift Table

Total Suction Head (metres)	Total Delivery Head (metres)				
	35	50	65	75	85
	Output (m³/hr)				
3.0	250	240	215	185	150
4.6	250	240	210	180	140
6.1	196	180	150	130	110
7.6	144	135	120	100	60

Fuel capacity (Full) 390 litres, (Usable) 318 litres

Fuel consumption @ 2000 rpm BEP 17 litres/hour

Weight: (Dry) 1,900 kg, (Wet) 2,233 kg

Dimensions: (L) 2,500 x (W) 1,300 x (H) 1,900 mm

Performance data provided in tables is based on water tests at sea level and 20°C ambient. All information is approximate and for general guidance only. Please contact the factory or office for further details.

HL125M - Perkins 1106D-E66TA

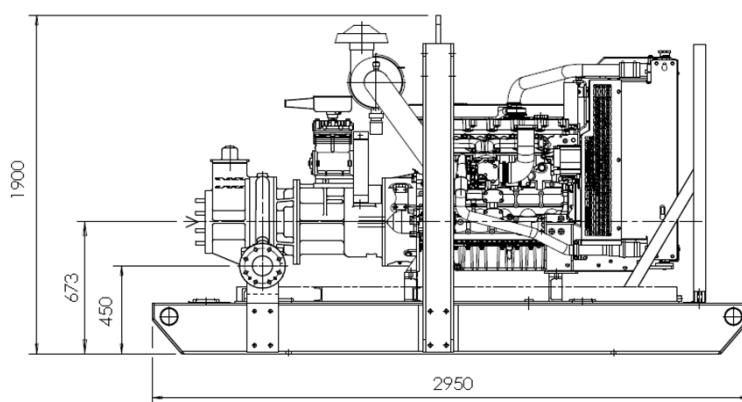
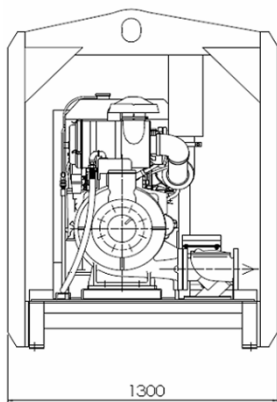

Xylem Dewatering Solutions UK Ltd
 Quenington, Cirencester
 Gloucestershire GL7 5BX, England
 Tel: 01285 750271 Fax: 01285 750352



Assessed to ISO 9001:2008
 Certificate N° 1027

Reference number : 95-1110-1000
 Date of issue : 05 December 2012
 Issue : 9

www.godwinpumps.com