

# HL200M Dri-Prime® Pump

The Godwin Dri-Prime HL200M pump is an extremely powerful yet compact pump with flow capabilities to 635 m<sup>3</sup>/hr and discharge heads to 117 metres.

The HL200M features the unique Godwin high pressure oil bath mechanical seal design. This allows for dry running for prolonged periods while automatically priming and repriming. Able to perform in the toughest conditions, the HL200M can handle solids up to 38 mm in diameter. This makes it an extremely effective pump, suitable for both slurry and clean water applications. The powerful HL200M has proven itself a pump of choice for mines, quarries and many other high capacity applications.



## Features and Benefits

- Fully automatic priming from dry to 8.5 metres suction lift.
- Godwin Dri-Prime is a continuously operated Venturi air ejector priming device which requires no periodic adjustment or control.
- Extensive application flexibility. It will handle sewage, slurries and liquids with solids up to 38 mm in diameter.
- Dry-running high pressure oil bath mechanical seal, with high abrasion resistant silicon carbide faces.
- A Close-coupled centrifugal pump with Godwin Dri-Prime system mounted to a diesel engine or electric drive.
- All cast iron construction (stainless steel construction option available) with cast steel impeller.
- Also available as Hush-Pac or as a bareshaft pumpend.
- Standard build engines; Caterpillar C9, Perkins 1106D-E66TA (168). Other engine options are available.

## Specifications

Suction connection	200 mm (8" BS10 table 'D')
Delivery connection	150 mm (6" BS EN 1092 PN16)
Max capacity	635 m <sup>3</sup> /hr
Max Head	117 metres
Max Solids handling	38 mm
Max Impeller diameter	400 mm
Max operating temp	80 °C
Max working pressure	11.6 bar
Max suction pressure	6.0 bar
Max casing pressure	17.4 bar
Max operating speed	2200 rpm

godwin   
a xylem brand

# Performance Curve

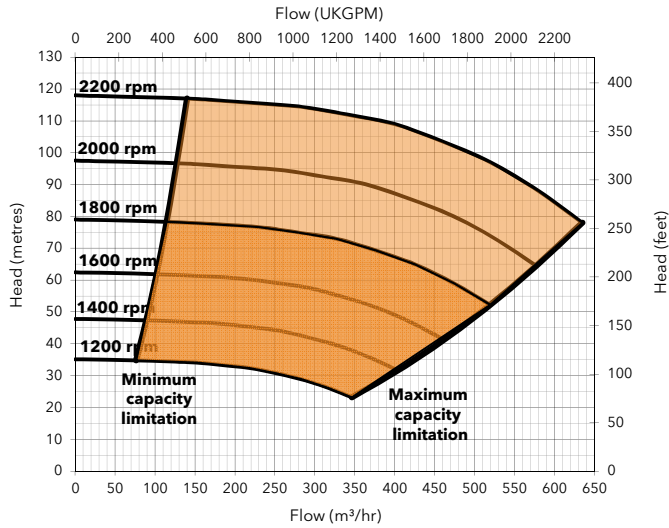

## Engine option 1

Price list ref - HL200M-01-DBO-003

Caterpillar, C9, 205.0 kW @ 2200 rpm

Impeller diameter 400 mm

Pump Speed 2200 rpm

### Suction Lift Table

Total Suction Head (metres)	Total Delivery Head (metres)				
	77	87	98	105	113
	Output (m³/hr)				
3.0	629	566	492	409	157
4.6	569	558	471	398	126
6.1	503	482	452	377	105
7.6	314	308	298	287	-

Fuel capacity (Full) 850 litres, (Usable) 690 litres

Fuel consumption @ 2200 rpm BEP 55 litres/hour

Weight: (Dry) 4,019 kg, (Wet) 4,750 kg

Dimensions: (L) 3,700 x (W) 1,700 x (H) 2,200 mm

Performance data provided in tables is based on water tests at sea level and 20°C ambient. All information is approximate and for general guidance only. Please contact the factory or office for further details.

# Materials

Pump casing & suction cover	Cast iron BS EN 1561 - 1997
Wearplates	Cast iron BS EN 1561 - 1997
Pump Shaft	Carbon steel BS EN 1561 - 1997
Impeller	Cast Steel BS3100 A5 Hardness to 200 HB Brinell
Non-return Valve body	Cast Iron BS EN 1561 - 1997
Mechanical Seal Faces	Silicon carbide vs silicon carbide

## Engine option 2

Price list ref - HL200M-01-DBO-002

Perkins, 1106D-E66TA (168), 143.6 kW @ 1800 rpm

Impeller diameter 400 mm

Pump Speed 1800 rpm

### Suction Lift Table

Total Suction Head (metres)	Total Delivery Head (metres)				
	49	56	63	68	73
	Output (m³/hr)				
3.0	514	463	403	334	129
4.6	465	457	386	326	103
6.1	411	394	370	309	86
7.6	257	252	244	235	-

Fuel capacity (Full) 475 litres, (Usable) 388 litres

Fuel consumption @ 1800 rpm BEP 37 litres/hour

Weight: (Dry) 3,600 kg, (Wet) 4,300 kg

Dimensions: (L) 2,950 x (W) 1,300 x (H) 1,900 mm

Performance data provided in tables is based on water tests at sea level and 20°C ambient. All information is approximate and for general guidance only. Please contact the factory or office for further details.

HL200M - Caterpillar C9

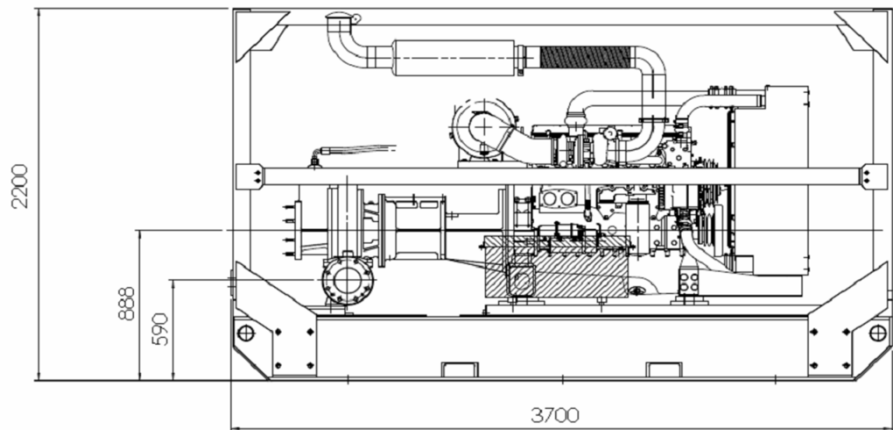
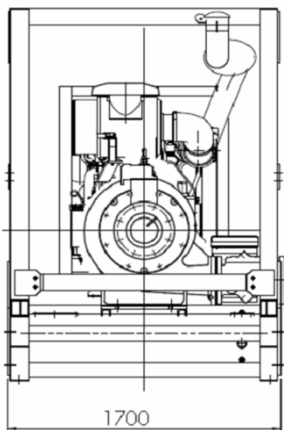

Xylem Dewatering Solutions UK Ltd  
 Quenington, Cirencester  
 Gloucestershire GL7 5BX, England  
 Tel: 01285 750271 Fax: 01285 750352



Assessed to ISO 9001:2008  
 Certificate N° 1027

Reference number : 95-1112-1000  
 Date of issue : 05 December 2012  
 Issue : 12

[www.godwinpumps.com](http://www.godwinpumps.com)