

Performance Curve

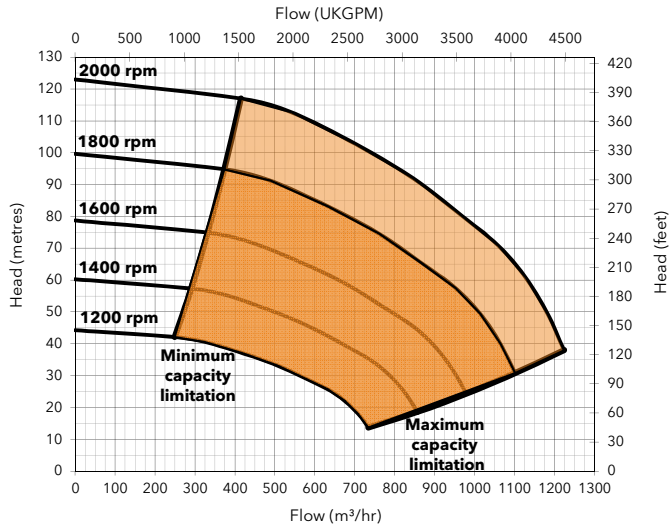

Engine option 1

Price list ref - HL250M-01-DBO-001

Caterpillar, C15, 315.0 kW @ 2000 rpm

Impeller diameter 440 mm

Pump Speed 2000 rpm

Suction Lift Table

Total Suction Head (metres)	Total Delivery Head (metres)				
	38	53	76	96	114
	Output (m³/hr)				
3.0	1215	1150	975	760	450
4.6	1200	1142	950	750	375
6.1	1100	1050	952	720	330
7.6	875	850	800	683	-

Fuel capacity (Full) 1225 litres, (Usable) 993 litres

Fuel consumption @ 2000 rpm BEP 77 litres/hour

Weight: (Dry) 5,840 kg, (Wet) 7,000 kg

Dimensions: (L) 4,000 x (W) 1,950 x (H) 2,350 mm

Performance data provided in tables is based on water tests at sea level and 20°C ambient. All information is approximate and for general guidance only. Please contact the factory or office for further details.

Materials

Pump casing & suction cover	Cast iron BS EN 1561 - 1997
Wearplates	Cast Iron BS EN 1561 - 1997
Pump Shaft	Carbon steel BS EN 1561 - 1997
Impeller	Cast Steel BS3100 A5 Hardness to 200 HB Brinell
Non-return Valve body	Cast Iron BS EN 1561 - 1997
Mechanical Seal Faces	Silicon carbide vs silicon carbide

Engine option 2

Price list ref - HL250M-01-DBO-003

Volvo, TAD1251VE, 269.0 kW @ 1800 rpm

Impeller diameter 440 mm

Pump Speed 1800 rpm

Suction Lift Table

Total Suction Head (metres)	Total Delivery Head (metres)				
	28	41	59	75	90
	Output (m³/hr)				
3.0	1094	1035	878	684	405
4.6	1080	1028	855	675	338
6.1	990	945	857	648	297
7.6	788	765	720	615	-

Fuel capacity (Full) 1225 litres, (Usable) 993 litres

Fuel consumption @ 1800 rpm BEP 57 litres/hour

Weight: (Dry) 5,340 kg, (Wet) 6,460 kg

Dimensions: (L) 4,000 x (W) 1,950 x (H) 2,350 mm

Performance data provided in tables is based on water tests at sea level and 20°C ambient. All information is approximate and for general guidance only. Please contact the factory or office for further details.

HL250M CAT C15 ACERT

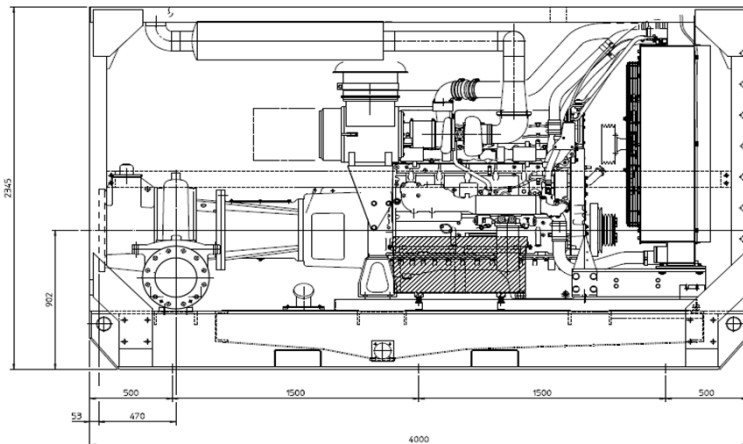
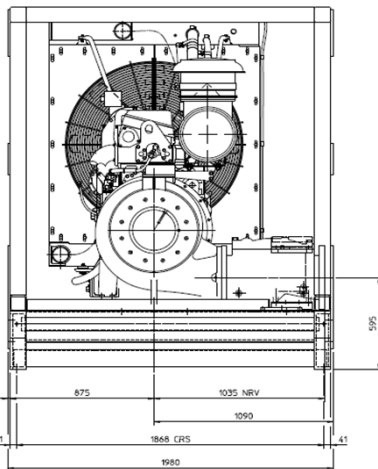

Xylem Dewatering Solutions UK Ltd
 Quenington, Cirencester
 Gloucestershire GL7 5BX, England
 Tel: 01285 750271 Fax: 01285 750352



Assessed to ISO 9001:2008
 Certificate N° 1027

Reference number : 95-1114-1000
 Date of issue : 05 December 2012
 Issue : 11

www.godwinpumps.com