

Data sheet KTD33.0-53

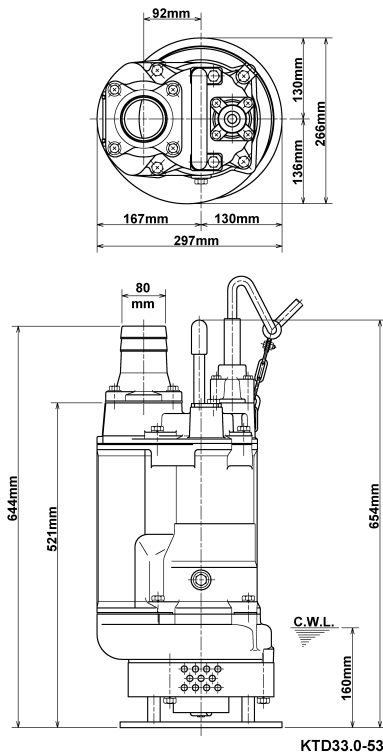

CWL: Continuous running water level

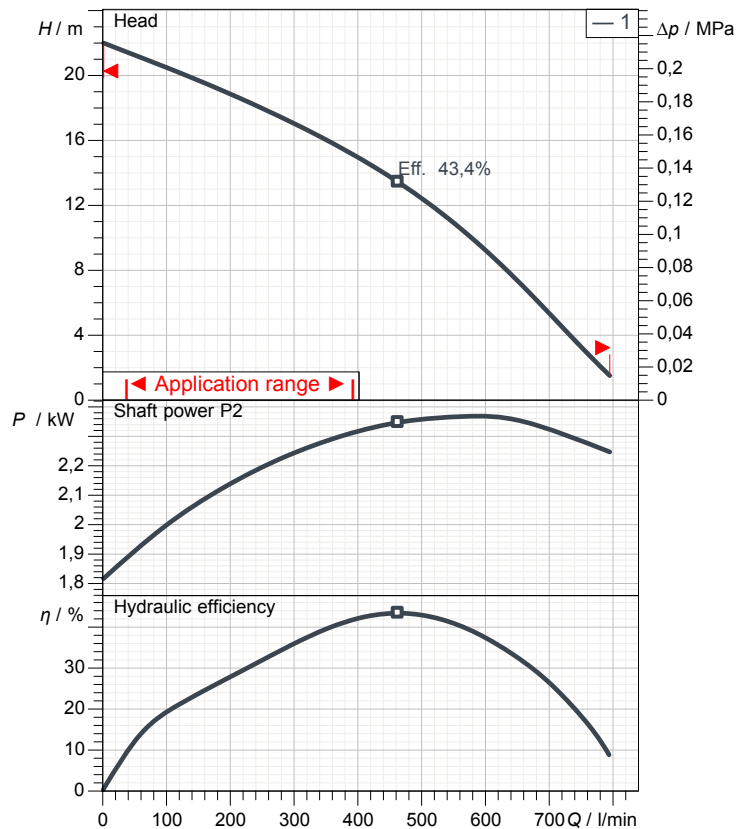

Specification

Electric submersible pump with agitator
 Degree of protection IP 68
 Pressure resistance max. 25 m
 Type of impeller Semi-open
 Max. solid handling 10 mm
 Suitable for:
 spring-/rain-/waste-/ground water, water containing sand

Electric motor

Dry-type submersible induction motor
 Insulation class F 2Poles 2850 1/min
 Starting mode Direct starting
 Rated voltage 400 V 50 Hz 3~
 Power uptake 3,98 kW
 Rated power 3,00 kW
 Rated current 6,5 A
 Start current 58,0 A

Cable

20m NSSHÖU 4Cx1,5mm²

Motor Protection

Circle thermal protector
 (snap-action bi-metal device)

Shaft seal

Double inside mechanical seal in oil bath
 additional lubrication by oil lifting device
 Primary seal
 Silicon carbide on silicon carbide
 Secondary seal
 Silicon carbide on carbon

Bearings

Shielded ball bearings, maintenance-free

Materials

Impeller	Chromium iron casting
Agitator	FCD700 (EN-GJS-700-2)
Pump casing	FC200 (EN-GJL-200)
Suction cover	FCD50 (EN-GJS-500-7)
Motor Frame	FC150 (EN-GJL-150)
Shaft	SUS420J2 (EN-X30Cr13)

Discharge size

3" (80mm) BS-coupling (threaded flange)

Weight

65 kg (dry weight of the pump only without cable)

Performance curve

KTD33.0-53

Discharge port	3"
Head	22,0 m
Flow	794,9 l/min
Rated power	3,00 kW
Power input	3,98 kW
Phases	3~
Voltages	400 V
Frequency	50 Hz
Rated current	6,5 A
Starting current	57,98 A
Number of poles	2
Speed	2850 1/min
Starting mode	Direct starting
Insulation class	F

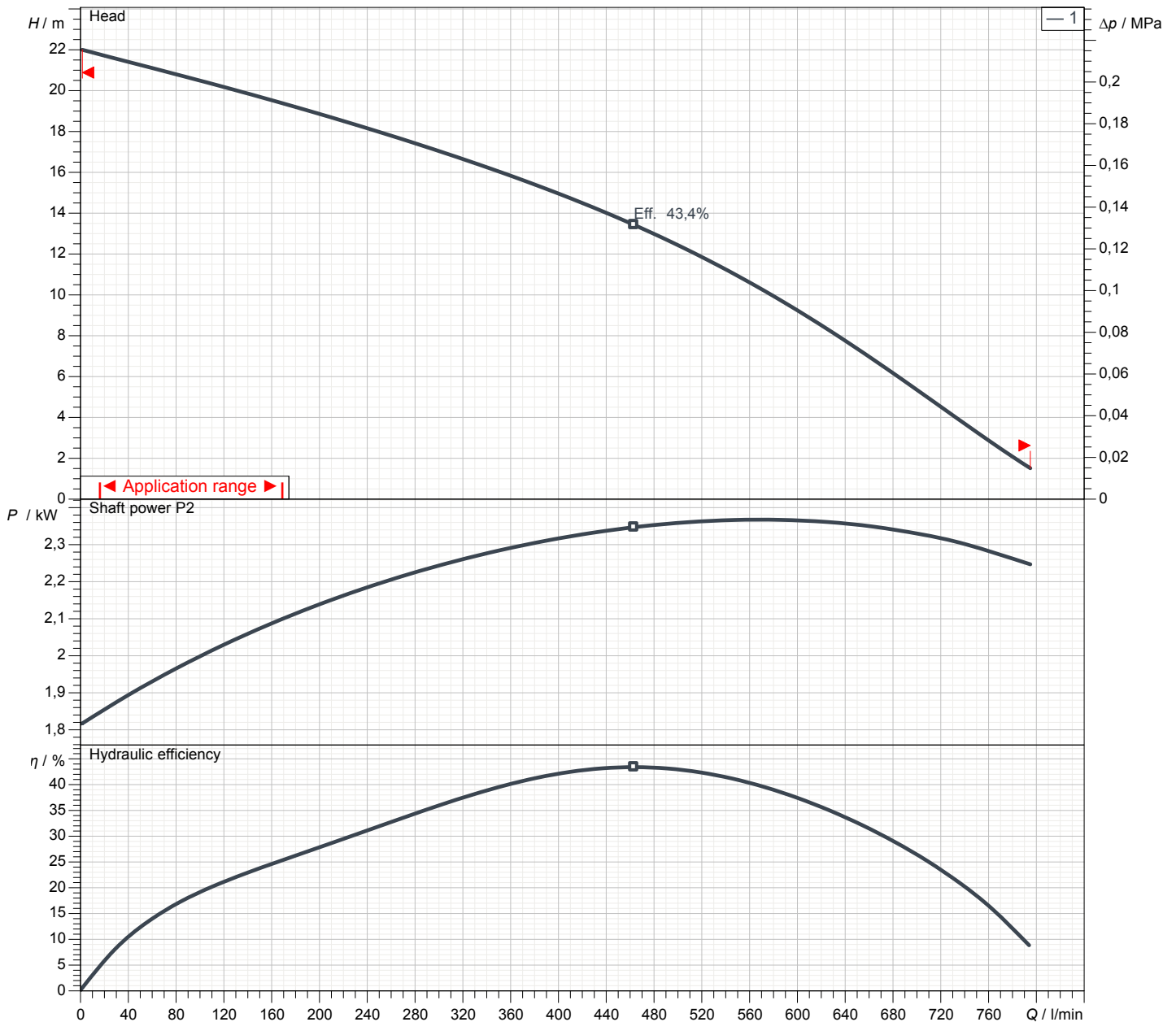

Dimensions

KTD33.0-53

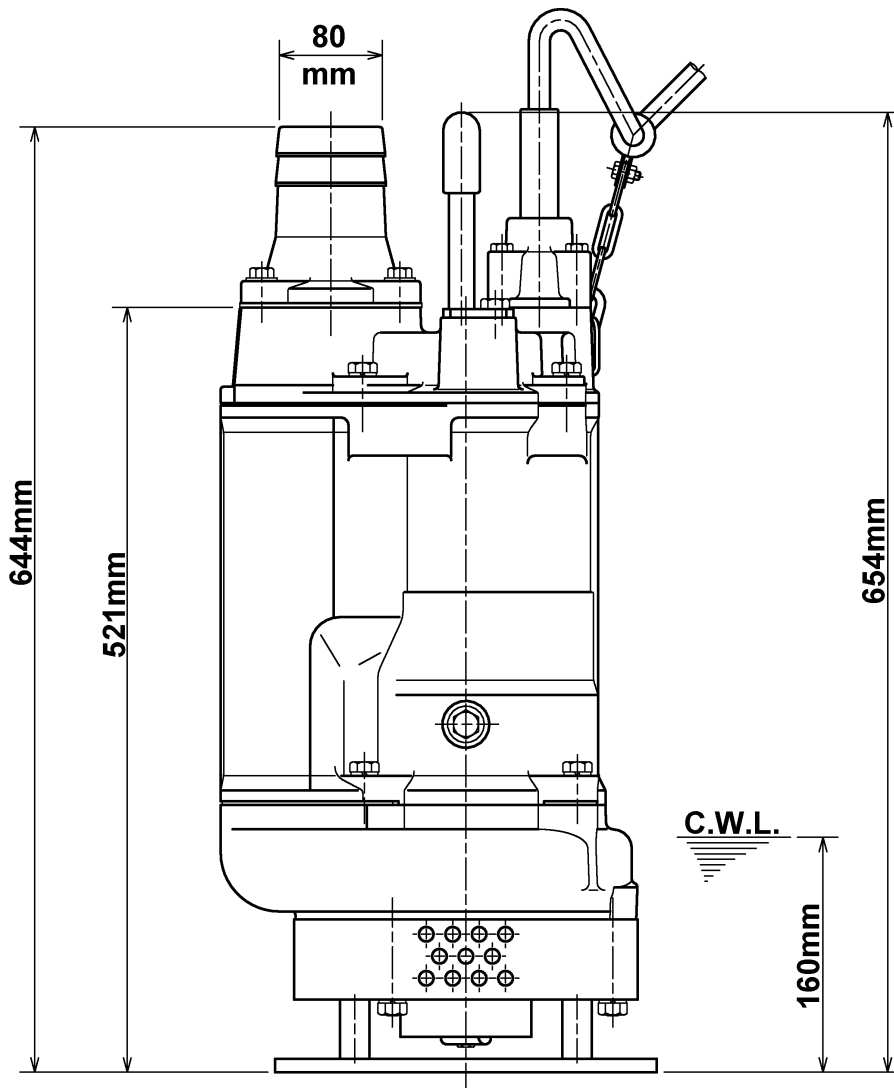
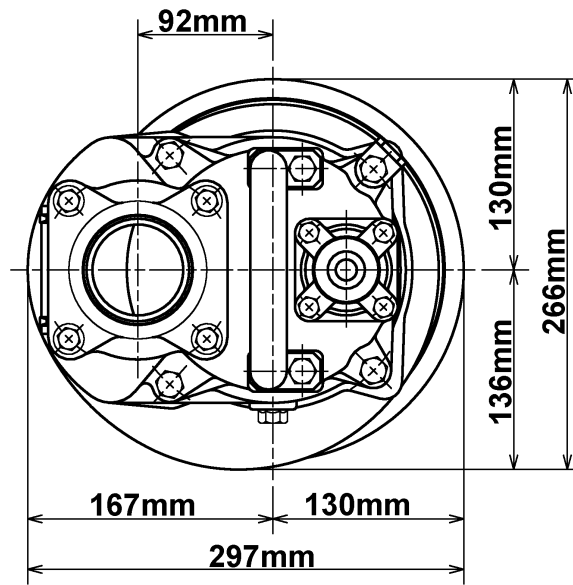

KTD33.0-53

CWL: Continuous running water level
LWL: Lowest running water level

Sectional drawing KTD33.0-53

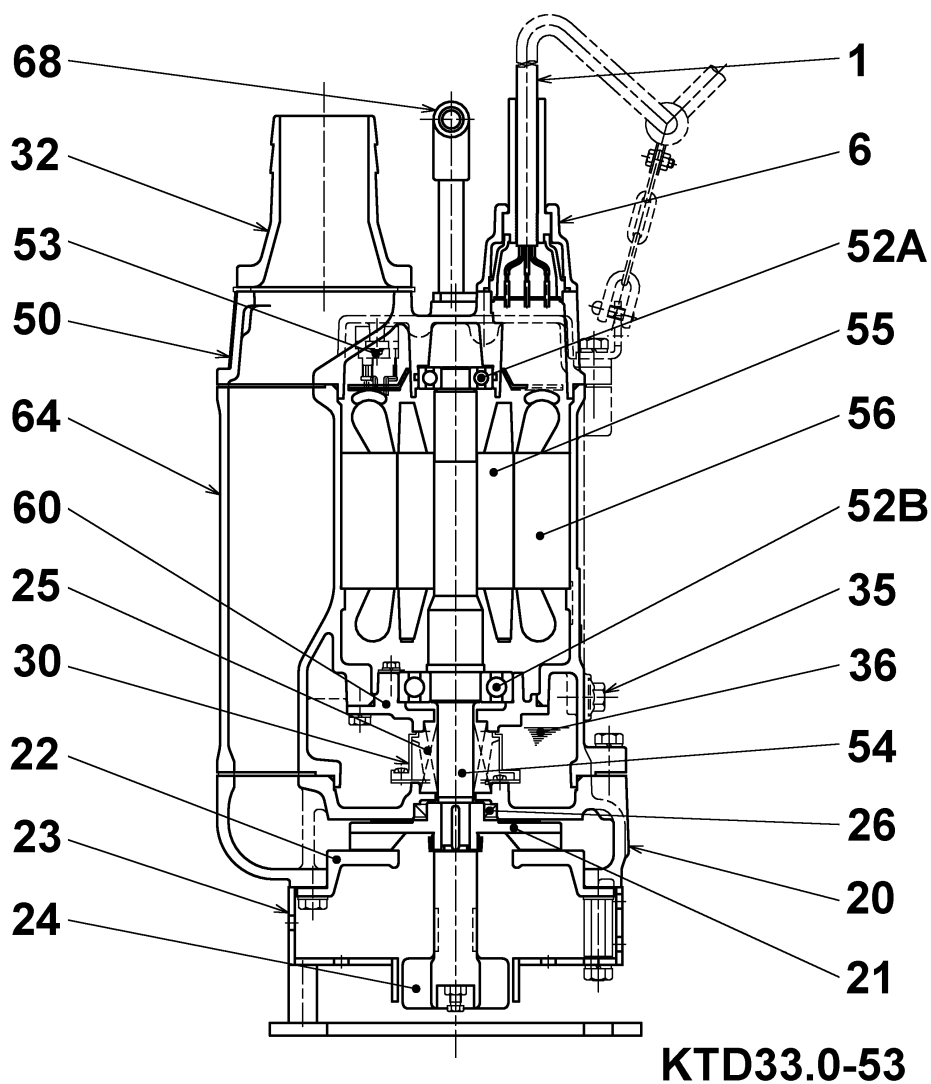

KTD33.0-53

No.	Description	Remark	No.	Description	Remark
1	Cable	20m NSSHÖU	53	Motor Protector 380/400/415V-50Hz.KA314-HRXL00 (H.C)	
6	Stuffing box	FC200 (EN-GJL-200)	54	Shaft	SUS420J2 (EN-X30Cr13)
20	Pump casing	FC200 (EN-GJL-200)	55	Rotor	.
21	Impeller	Chromium iron casting	56	Stator	.
22	Suction cover	FCD50 (EN-GJS-500-7)	60	Bearing Housing	FC150 (EN-GJL-150)
23	Strainer	Steel plate	64	Motor Frame	FC150 (EN-GJL-150)
25	Mechanical seal	H-25T	68	Handle	steel pipe / Sectional steel
24	Agitator	FCD700 (EN-GJS-700-2)			
26	Oil seal	TC40588			
30	Oil distributor	Plastic			
32	Discharge coupling	Aluminium alloy casting			
35	Oil screw	SUS304 (EN-X5CrNi18-10)			
36	Lubricant	Turbine oil (ISO VG32)			
50	Main cover	FC150 (EN-GJL-150)			
52A	Upper bearing	6304ZZC3			
52B	Lower bearing	6307ZZC3			