

Xylem Water Solutions AB (the Company) was previously named ITT Water & Wastewater AB. The name change took place in November 2011. This is document is (i) a document that relates to a product of the Company phased out prior to the name change; or (ii) an old version of documentation relating to a product that is still being produced by the Company but which document was published prior to the 1st of January 2012 . This document may therefore still be marked "ITT". Xylem Water Solutions AB is no longer an ITT company and the fact that "ITT" may appear on this document shall not be interpreted as a reference by the Company to "ITT" in the Company's current business activities. Any use or reference to "ITT" by you is strictly prohibited. In no event will we be liable for any incidental, indirect, consequential, punitive or special damages of any kind, or any other damages whatsoever, including, without limitation, those resulting from loss of profit, loss of contracts, loss of reputation, goodwill, data, information, income, anticipated savings or business relationships for any use by you of "ITT". This disclaimer notice shall be interpreted and governed by Swedish law, and any disputes in relation to it are subject to the jurisdiction of the courts in Sweden. If you do not agree to these terms and conditions you should not print this document and immediately stop accessing it.

End of Disclaimer text.



Technical Specification

2201.590, 2201.690



2201.590.690 Technical specification

The 2201.590.690 is an explosion-proof submersible drainage pump for high delivery heads and large volumes.

The pump is particularly suitable for demanding use within the mining and petrochemical industries.

The 2201.590.690 can pump liquids containing abrasive particles with a minimum of wear on the impeller and pump casing. The pump is compact and can be used in confined spaces.

The pump is easy to install and can run unattended. Wear parts can easily be adjusted or replaced to maintain full capacity even in the face of heavy water.

The BS 2201.590.690 is available in two versions:

MT = Medium-head version with capacity up to 150 l/s.

HT = High-head version for delivery heads up to 100 m.

The DS 2201.590.690, with vortex impeller, is available in one version:

ST = Superhigh-head version for delivery heads up to 130 m.

For higher delivery heads, two or three pumps can be connected in series.

APPLICATIONS

The 2201.590.690 is intended to be used for pumping water which may contain abrasive particles.

The 2201.590.690 is designed for use in explosive environments in accordance with the following approvals:

Européen Norm 590: EEx de IIB T3
(EN) 690: EEx de I
EEx de I (Sch)s

This pump is also available in two non-explosion-proof versions: 2201.011 and 2201.320. These pumps have the same high quality and performance as the 2201.590.690 and are manufactured in aluminium and cast iron, respectively.

Liquid temperature: max 40°C (103°F).

Liquid density: max 1 100 kg/m³.

The pH of the pumped liquid: 6—11.

The pumped liquid may contain particles up to a size which corresponds to the openings in the strainer.

For other applications, contact your nearest Flygt representative for information.

MOTOR DATA

Motor type: Squirrel-cage 3-phase a.c. motor, insulation class F.

Frequency 50 Hz

Output: 37 kW

Speed: 2 900 rpm

Voltage	Rated current
380 V	67 A
400 V	65 A
415 V	62 A
500 V	51 A
550 V	47 A
660 V	39 A
690 V	37 A
1 100 V	23 A

Frequency 60 Hz

Output: 43 kW (58 hp)

Speed: 3 500 rpm

Voltage	Rated current
440 V	67 A
460 V	65 A
575 V	52 A

DIMENSIONS AND WEIGHTS

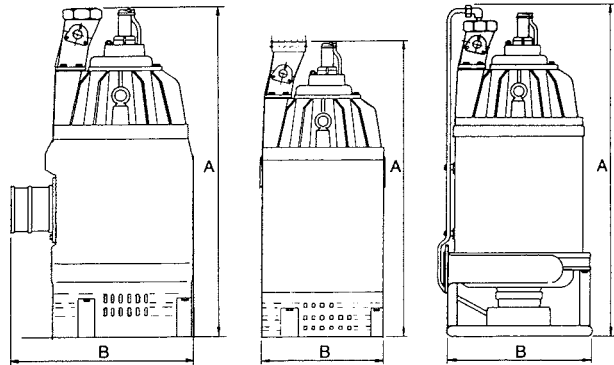

MT

A = 1 200 mm (48")

B = 640 mm (25")

HT

A = 1 050 mm (42")

B = 434 mm (17")

ST

A = 1 200 mm (48")

B = 495 mm (20")

Weight without motor cable:

MT

445 kg (980 lb)

HT

350 kg (770 lb)

ST

415 kg (915 lb)

Discharge connection:

MT: 6", 8", 6" BSP, 8" BSP, NPT6", NPT8"

HT: 4" BSP, 4—8 NPSM

ST: 40 mm diam. Flange 165 mm diam.

MATERIALS

		DIN	BS	AISI
Cast parts	Cast iron	1691 GG25	1452:1956 Grade 17	ASTM A 48—64 No 40 B
Shaft	Stainless steel	17440 X20 Cr 13	970:4 420s37	420
Impeller, MT	Chromium-alloyed cast iron	G-X260 Cr 27	4844 Grade 3E	ASTM 532—80 Alloy 111 A
Impeller, HT	1) Forged spring steel	17221 50 Cr V4	EN 47	6150
	2) Forged stainless steel	1.4571	A 12 Ti	316 Ti
	3) Chromium-alloyed cast iron	G-X260 Cr 27	4844 Grade 3E	ASTM 532-80 Alloy 111 A
Impeller, ST	Ni-hard 4		4844 Grade 2D	ASTM A 532-75 (I-D)
Wear parts, MT, HT	Nitrile-rubber-covered			
Wear ring, ST	Ni-hard 4		4844 Grade 2D	ASTM A 532-75 (I-D)
Pump casing, ST	Ni-hard 4		4844 Grade 2D	ASTM A 532-75 (I-D)

Sealing surfaces, inner seal Tungsten carbide—Carbon.

Sealing surfaces, outer seal Tungsten carbide—Tungsten carbide.

DESIGN

1. Junction box

The junction box is completely sealed off from the surrounding liquid and from the motor unit.

2. Cooling

A built-in cooling system enables the pump to work continuously at its rated output regardless of whether the electric motor is above or below the surface of the liquid.

The pumped liquid is circulated from the pump casing up between the cooling jacket and the stator casing and removes heat generated by the motor.

Air between the outer casing and the stator casing is evacuated through a valve on the top part of the pump.

3. Motor

Motor insulation to Class F means a maximum working temperature of 155°C (310°F) and permits a temperature rise of 100°C (210°F).

The temperature rise in Flygt motors does not normally exceed 80°C (180°F). The insulation material is chosen with the greatest care, and most materials are classified as Class H (180°C, 360°F) materials or very close to Class H. This means an expected service life far beyond what is required for Class F by IEC 85.

4. Monitoring system

The stator incorporates three thermal switches connected in series.

The thermal switches open at 110°C (230°F).

5. Oil casing

The oil lubricates and cools the seals and acts as a buffer between the pumped liquid and the electric motor.

Pressure build-up within the oil casing is reduced by means of a built-in air volume.

6. Bearings

The lower bearing consist of two single-row angular contact ball bearings.

The upper bearing consists of one deep-groove ball bearing.

The pump bearings are designed for at least 15 000 hours of operation.

7. Shaft seals

The pump has two mechanical seals.

These seals work independently of each other and seal off the motor from the pump unit.

8. Impellers

The pump is available with the following types of impellers:

Mixed-flow impeller, MT version

Radial-flow impeller, HT version

Vortex impeller, ST version

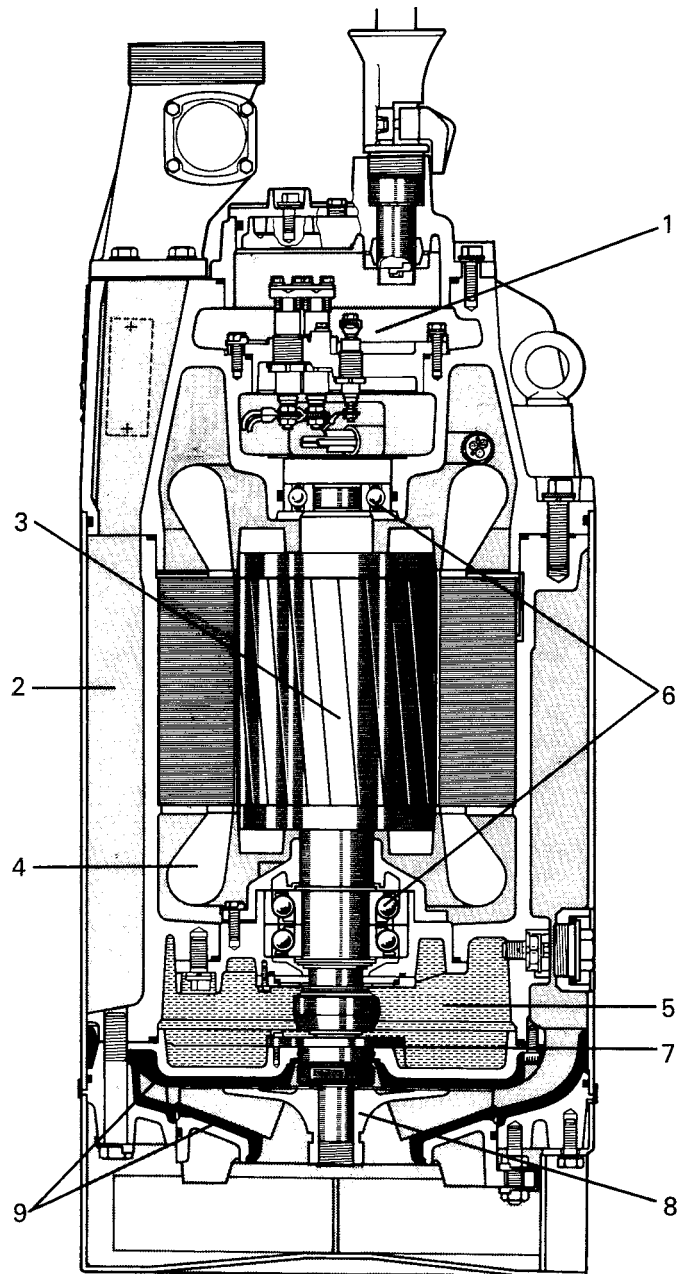

9. Wear parts

MT and HT versions

The pump's easily replaceable wear parts are rubber-covered.

By means of a simple adjustment, the capacity of the pump can be maintained even in the face of heavy wear.

ST version

The impeller is surrounded by a replaceable wear ring.

The wear ring and the pump casing are made of a highly durable material, Ni hard 4.

Adjustment of the impeller or parts of the casing is therefore not necessary.

PERFORMANCE CURVES

⌊ = Optimum operation point

50 Hz MT, HT

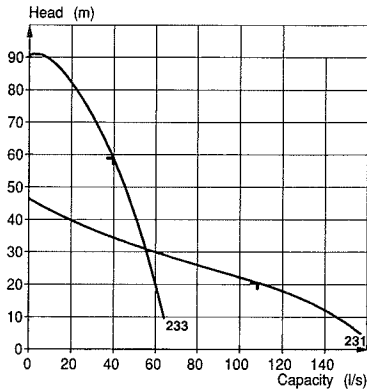
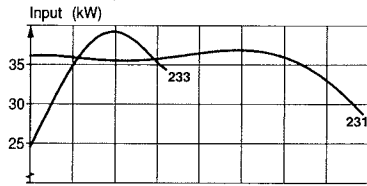

50 Hz ST

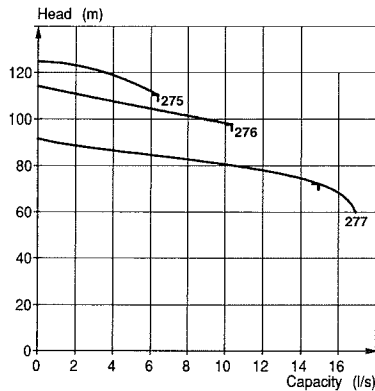
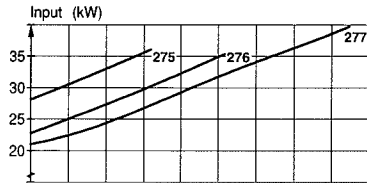

60 Hz MT, HT

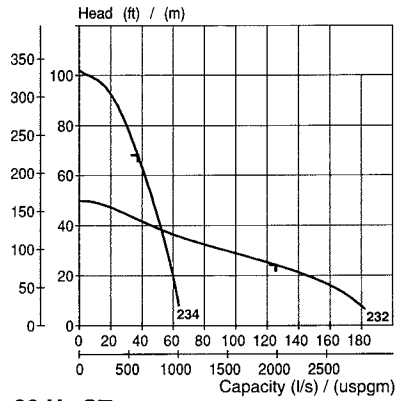
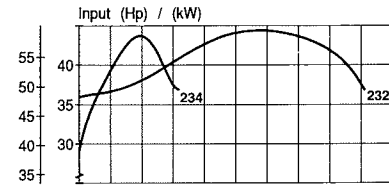

60 Hz ST

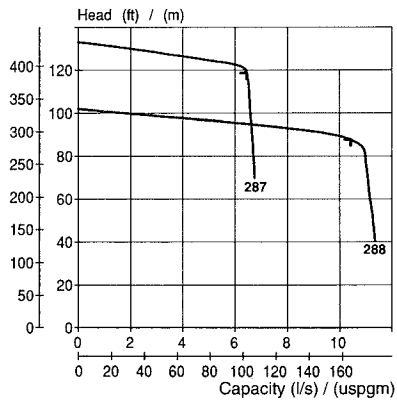
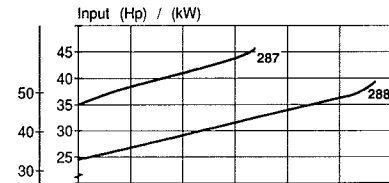

ACCESSORIES

Tandem operation

The delivery head can be increased by connecting two or three pumps in tandem. For this purpose, a tandem flange unit is available from Flygt.

Max. permissible operating pressure is 1.2 MPa for the MT and HT versions and 1.7 MPa for the ST version.

The vertical distances between the pumps should be approximately equal. Contact Flygt for further information.

Start and control equipment

Flygt has suitable start and control equipment for the pump.

Contact Flygt for further information.

Zinc anode set

In order to reduce corrosion, the pump can be fitted with zinc anodes.



The manufacturer reserves the right to alter performance, specification or design without notice.