

The B 2250: the pump for big jobs

Applications. The B 2250 is an electric, submersible, centrifugal pump intended for pumping clean or dirty water. The pump has very high capacity and is therefore suitable for major projects under heavy-duty conditions, e.g. on dam or harbour projects, power station construction, tunnelling, etc.

Control. The motor control should be a breaker of contactor type incorporating motor protection, or an automatic control switch with overload protection. Check that the overload protection is marked and set for a current not exceeding the rated current of the motor. The leads from the thermocontacts in the stator winding should be connected in series with the stop button of the motor control. Due to differing regulations in different countries it may be necessary to consult your local Flygt Agent.

Running. The B 2250 can be left without supervision for days and weeks at a time, running round the clock. It will suffer no damage if it runs dry. Abrasive particles in the water are no threat. A simple oil check once a month is all that is required.

Simple servicing. Wear parts are so easy to change that any of your own site personnel can do it. You can of course call upon the services of your local Flygt Engineer to do this work.

Tandem operation. If one pump is unable to cope with the required head, two or three pumps may be connected in tandem to multiply the delivery head.

How it is built

(figures refer to illustration)

1. F-Class stator with thermocontacts. The stator is designed to temperature class F (155°C). Thus it is highly heat-resistant and, furthermore, the insulating material employed is extra moisture-resistant. Embedded in the stator windings are two thermocontacts, arranged in series, which cut the control circuit in the event of overheating. The thermocontacts provide extra security in addition to the protection given by the overload relay in the motor control.

2. Shaft Seals of tungsten carbide, possess great resistance to abrasion.

3. Impeller of optimum hydraulic design. Highly durable: made of high-alloy cast steel with a hardness of 600 Brinell.

4. Easily-replaced, rubber-sheathed wear parts. Eventually even this pump will suffer some wear if the water is very dirty. Simple adjustment permits capacity to be restored, until the parts affected are totally worn out. Replacement is then a simple matter.

Technical data

Discharge connection for pipe or hose: Standard type, 10 in or 8 in. High-head type, 6 in.

Hose: Rubber with cord plies. Lengths available: 16½, 33 or 98 ft. (5, 10 or 30 m).

Motor: 3-phase a.c. motor, 54 kW (73 h.p.) at 1470 rev/min. 50 Hz. 200, 220, 380, 400, 415, 440, 500 or 550 V.

Rated current: 200 V: 200 A, 220 V: 180 A, 380 V: 105 A, 400 V: 100 A, 415 V: 96 A, 440 V: 91 A, 500 V: 80 A, 550 V: 73 A.

Motor cable: Supplied on request. For direct start, 380, 400, 415 and 440 V: 4×35 mm²; 500 and 550 V: 4×25 mm². For YD start, 200 and 220 V: 4×35 mm²; 380, 400, 415 and 440 V: 4×25 mm²; 500 and 550 V: 4×16 mm².

In addition, a 2×1.5 mm² cable is required for connecting the control circuit to the thermo-contacts in the stator. Due to differing local regulations in different countries, it may be necessary to contact your local Flygt agent.

Highest efficiency: Pump 80 %; Motor 89 %; Overall 71 %.

Weight of pump: 1,190 lb. (540 kg) without cable or hose.

The manufacturers reserve the right to alter performance specification or design without notice.

FLYGT PUMPS LTD

Colwick Nottingham NG4 2AN Tel. 241321 Telex 37316

DISTRIBUTORS IN IRELAND AND THE CHANNEL ISLES

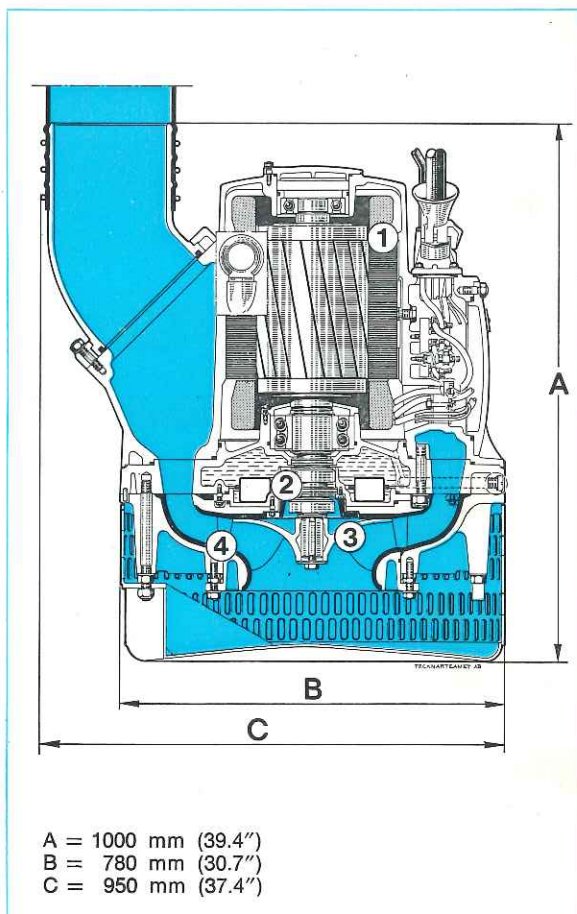
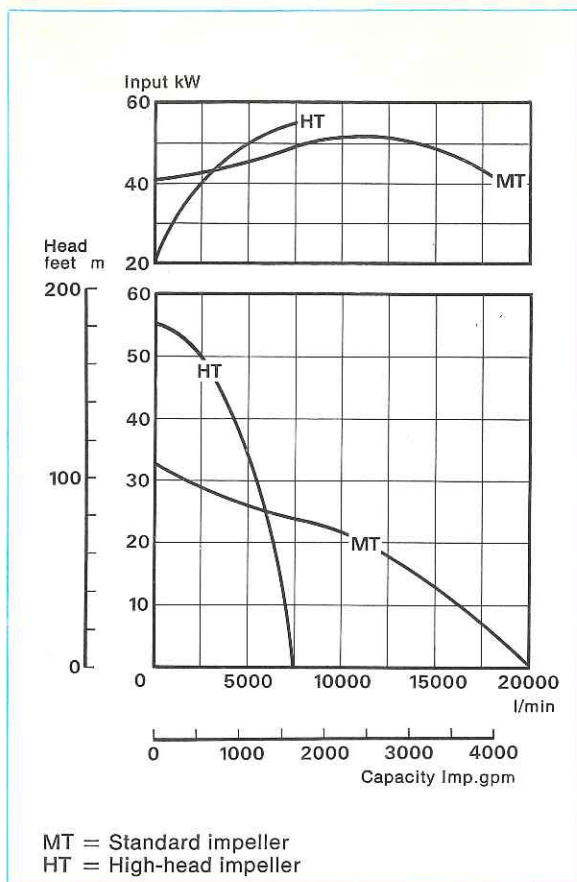

KINGS LANGLEY (Herts.) Tel. Kings Langley 64465
GRANGEMOUTH (Scotland) Tel. Grangemouth 3132
BRIDGWATER (Somerset) Tel. Bridgwater 51291/2
PONTARDAWE (S. Wales) Tel. Pontardawe 862055
THIRSK (Yorks.) Tel. Kirby Wiske 291
WATERLOOVILLE (Hants.) Tel. Waterlooville 54952
ASHFORD (Kent) Tel. Ashford 21122
ST. IVES (Hunts.) Tel. St. Ives 68851
LISKEARD (Cornwall) Tel. Liskeard 45099
INVERNESS (Inverness-shire) Tel. Inverness 32399
WARRINGTON (Lancs.) Tel. Padgate 821460